

NOTICE DE MONTAGE
INSTALLATION INSTRUCTIONS
MANUAL DE INSTALACION
MANUAL DE INSTALACAO
ISTRUZIONI DI MONTAGGIO
INSTALLATIE VOORSCHRIFTEN
INSTALLATIONSANLEITUNG

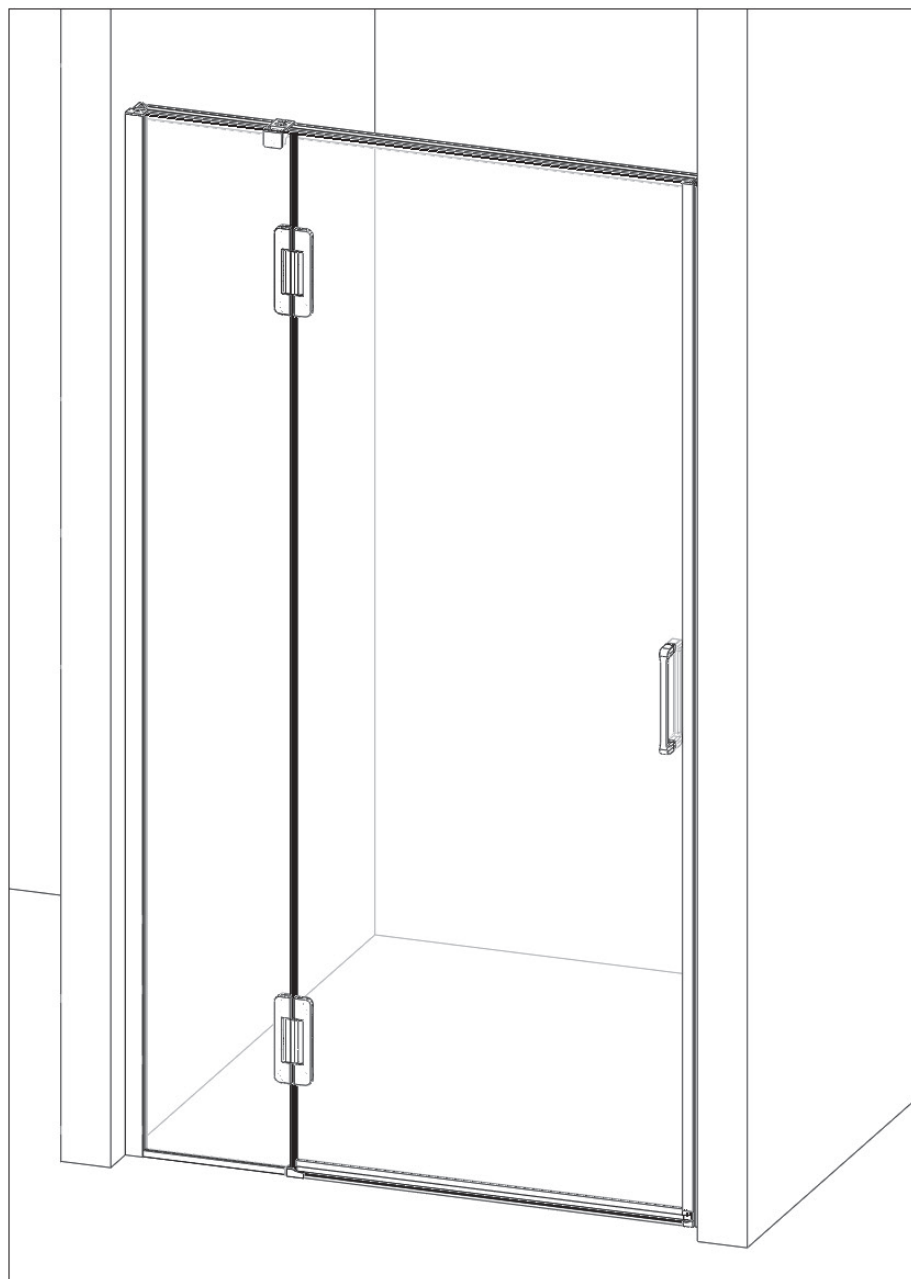



Attention aux étapes :
Check installation steps :
Atención a los pasos :
Atenção aos passos:
Attenzione ai passi :
Aandacht voor de stappen :
Achtung vor den Schritten :

P. 7 - 9 - 32

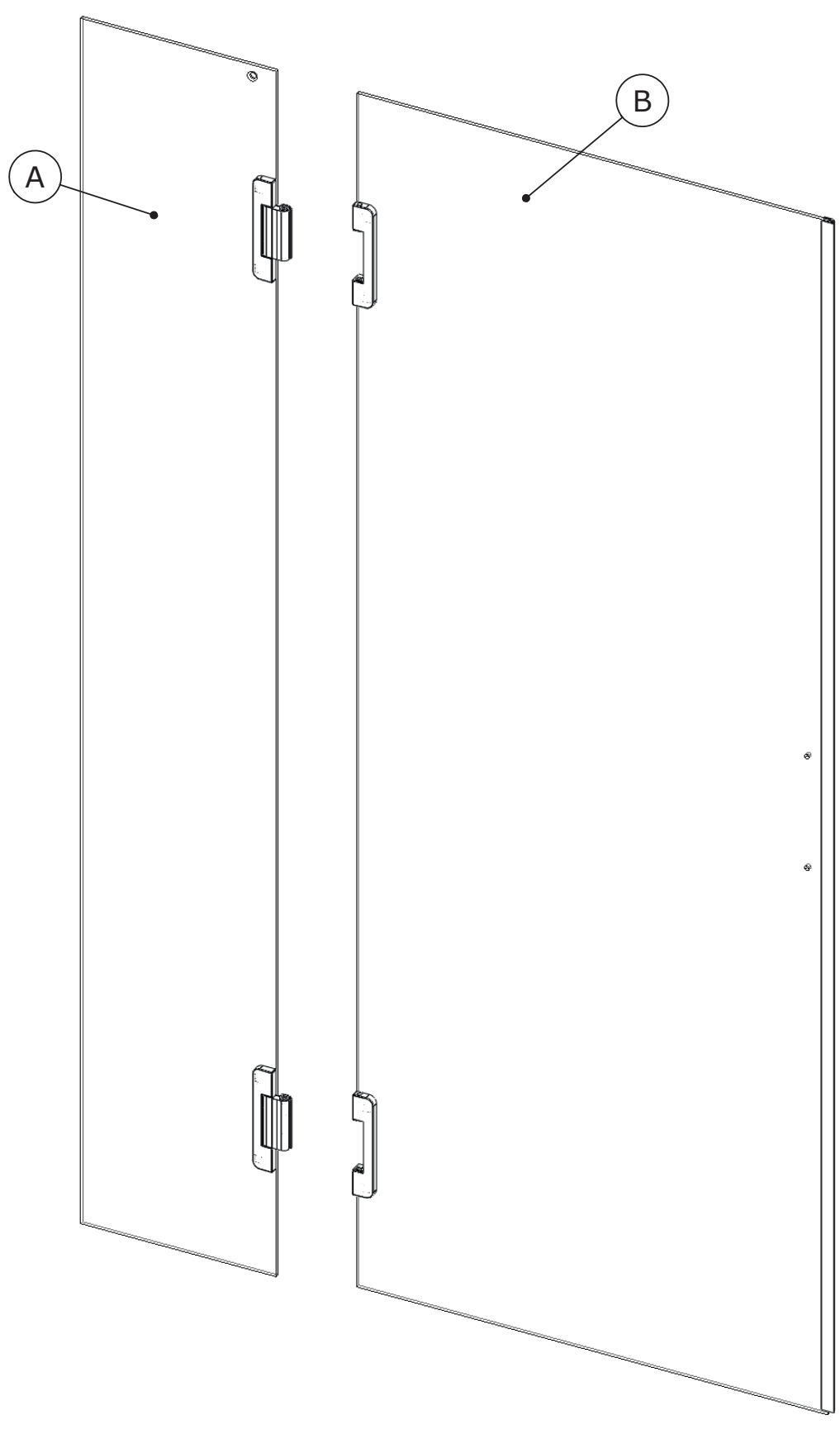
DES1460D

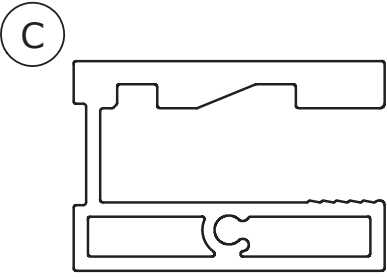
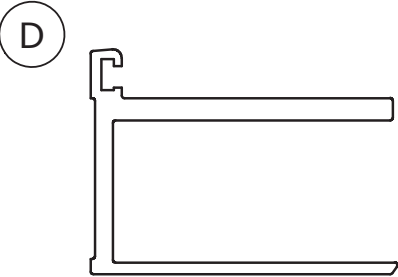

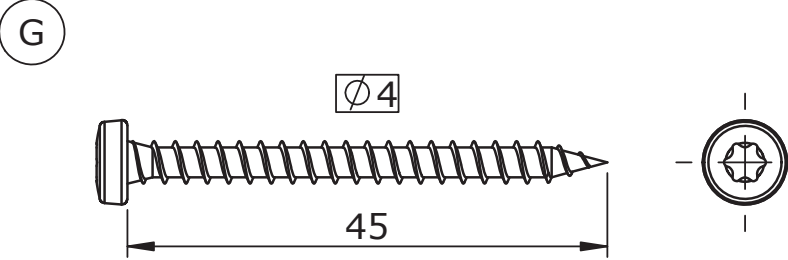
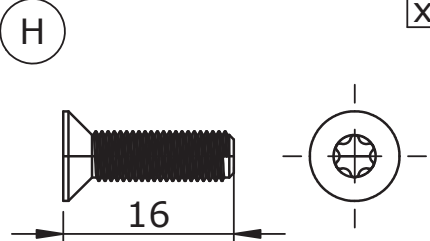
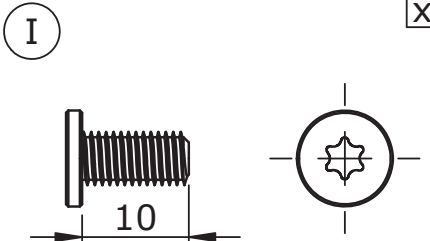
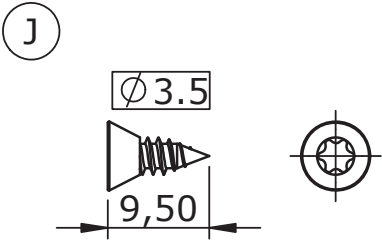
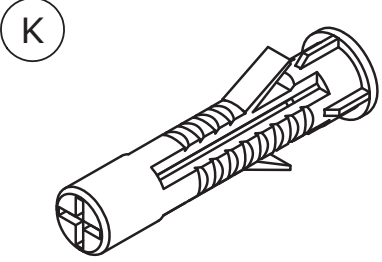
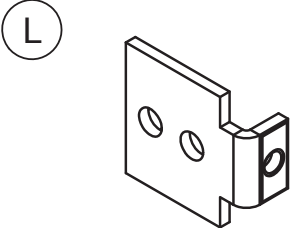
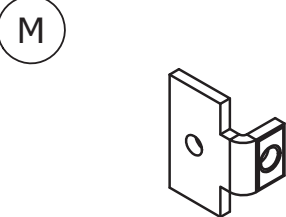
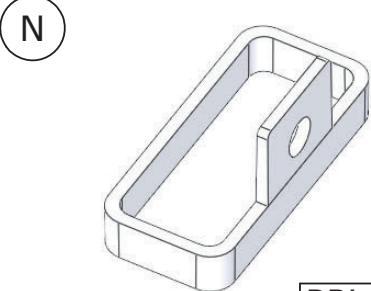
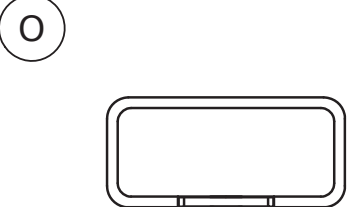
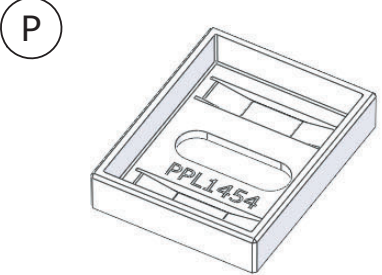
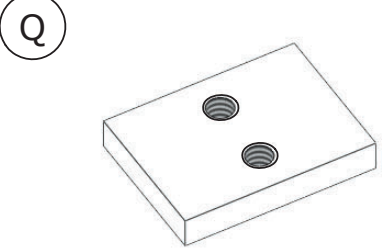
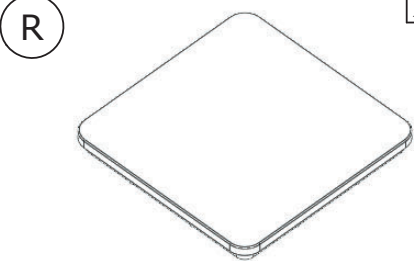
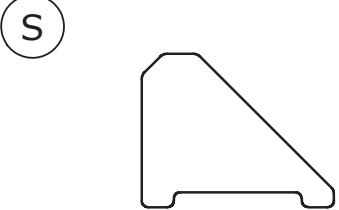
<p>C x1</p>  <p>6373</p>	<p>D x1</p>  <p>6377</p>	<p>E x1</p>  <p>6378</p>
<p>F x1</p>  <p>6379</p>	<p>G x8</p>  <p>$\varnothing 4$ 45</p> <p>VIS231</p>	
<p>H x3</p>  <p>16</p> <p>VIS278</p>	<p>I x3</p>  <p>10</p> <p>VIS275</p>	<p>J x2</p>  <p>$\varnothing 3.5$ 9,50</p> <p>VIS261</p>
<p>K x8</p>  <p>CHE02</p>	<p>L x1</p>  <p>EQU82</p>	<p>M x1</p>  <p>EQU83</p>
<p>N x1</p>  <p>PPL1452</p>	<p>O x1</p>  <p>Lg = 1850mm</p> <p>6372</p>	<p>P x1</p>  <p>PPL1454</p>
<p>Q x1</p>  <p>ECR100</p>	<p>R x1</p>  <p>PPL1461</p>	<p>S x1</p>  <p>Lg = 1050mm</p> <p>6285</p>

DES1460D

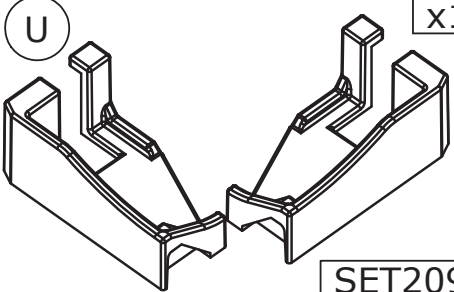
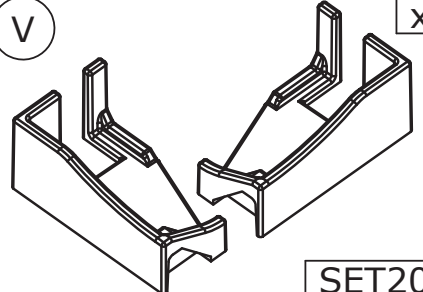
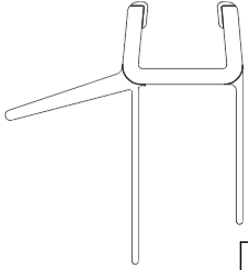
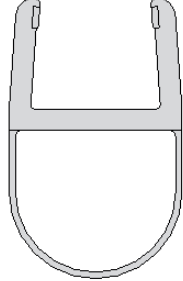
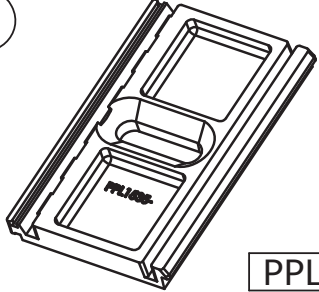
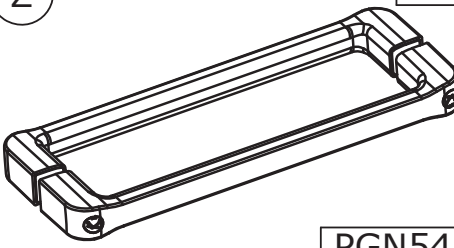
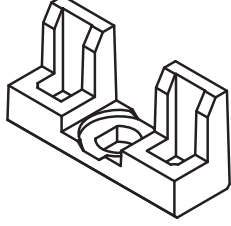
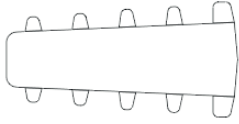
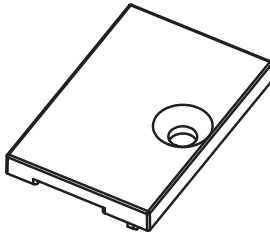
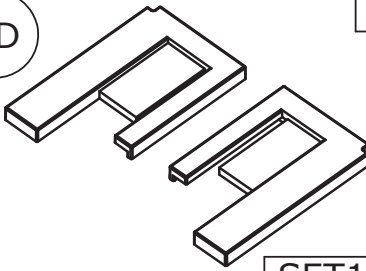
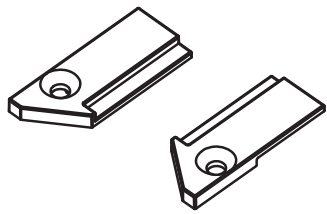
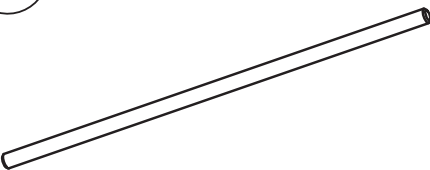
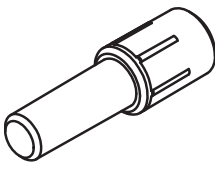
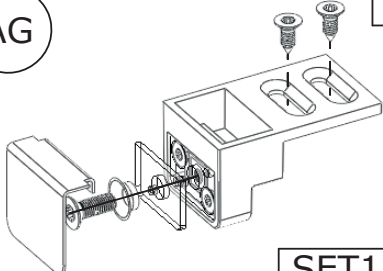
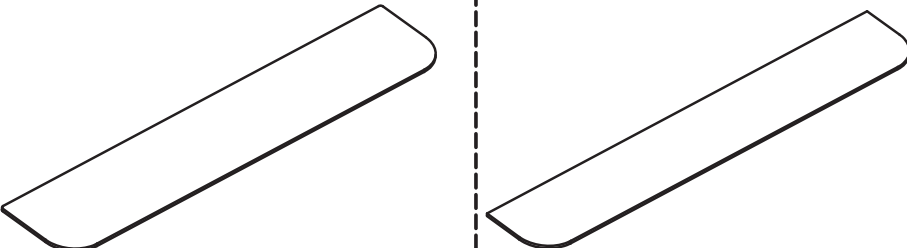
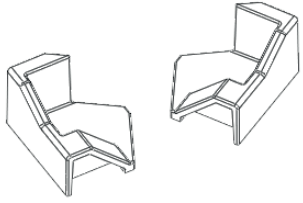
<p>(T)</p> <p>1200 ->1400mm x1 700 ->1000mm x2 1600 ->1800mm</p>  <p>6382</p>	<p>(U)</p>  <p>SET209</p>	<p>(V)</p>  <p>SET208</p>
<p>(W)</p>  <p>JOI322</p>	<p>(X)</p>  <p>JOI323</p>	<p>(Y)</p>  <p>PPL1535</p>
<p>(Z)</p>  <p>PGN54</p>	<p>(AA)</p>  <p>PPL1196</p>	<p>(AB)</p>  <p>JOI299</p>
<p>(AC)</p>  <p>PPL1453</p>	<p>(AD)</p>  <p>SET194</p>	<p>(AE)</p>  <p>SET193</p>
<p>(AF)</p>  <p>CHAR27-2</p>	<p>(AG)</p>  <p>SET187</p>	<p>(AH)</p>  <p>SET210</p>
 <p>SET210</p>		<p>(AH)</p>  <p>SET210</p>

Les quantités données sont les quantités utiles au montage. les sachets fournis contiennent des pièces supplémentaires.
 The quantities given are what are required for the installation. There may be some surplus in the package provide.
 Las cantidades indicadas son las cantidades necesarias para el montaje. Las bolsitas incluidas contienen piezas suplementarias.
 As quantidades indicadas são as quantidades necessárias para a montagem. Os sacos fechados contém peças adicionais.
 Le quantità fornite sono le quantità necessarie al montaggio. I sacchetti forniti contengono pezzi supplementari.
 De aangegeven aantallen zijn bestemd voor de montage. De bijgeleverde zakjes bevatten extra onderdelen.
 Die Mengenangaben beziehen sich auf die für die Montage nötigen Teile. Eventuell weitere beige packte Teile ignorieren.

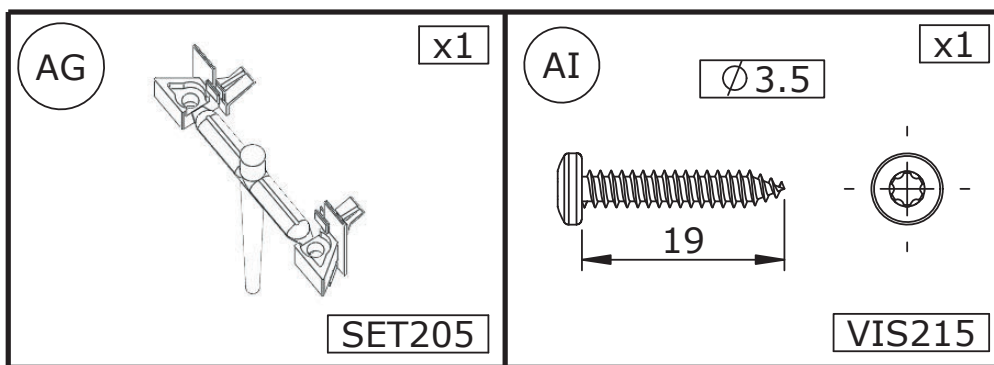

Les quantités données sont les quantités utiles au montage. les sachets fournis contiennent des pièces supplémentaires.
 The quantities given are what are required for the installation. There may be some surplus in the package provide.
 Las cantidades indicadas son las cantidades necesarias para el montaje. Las bolsitas incluidas contienen piezas suplementarias.
 As quantidades indicadas são as quantidades necessárias para a montagem. Os sacos fechados contêm peças adicionais.
 Le quantità fornite sono le quantità necessarie al montaggio. I sacchetti forniti contengono pezzi supplementari.
 De aangegeven aantallen zijn bestemd voor de montage. De bijgeleverde zakjes bevatten extra onderdelen.
 Die Mengenangaben beziehen sich auf die für die Montage nötigen Teile. Eventuell weitere beige packte Teile ignorieren.

**Matériel nécessaire - Tools required - Material necesario - Equipamento necessário
 Materiale necessario - Benodigdheden - Erforderliche Werkzeuge**

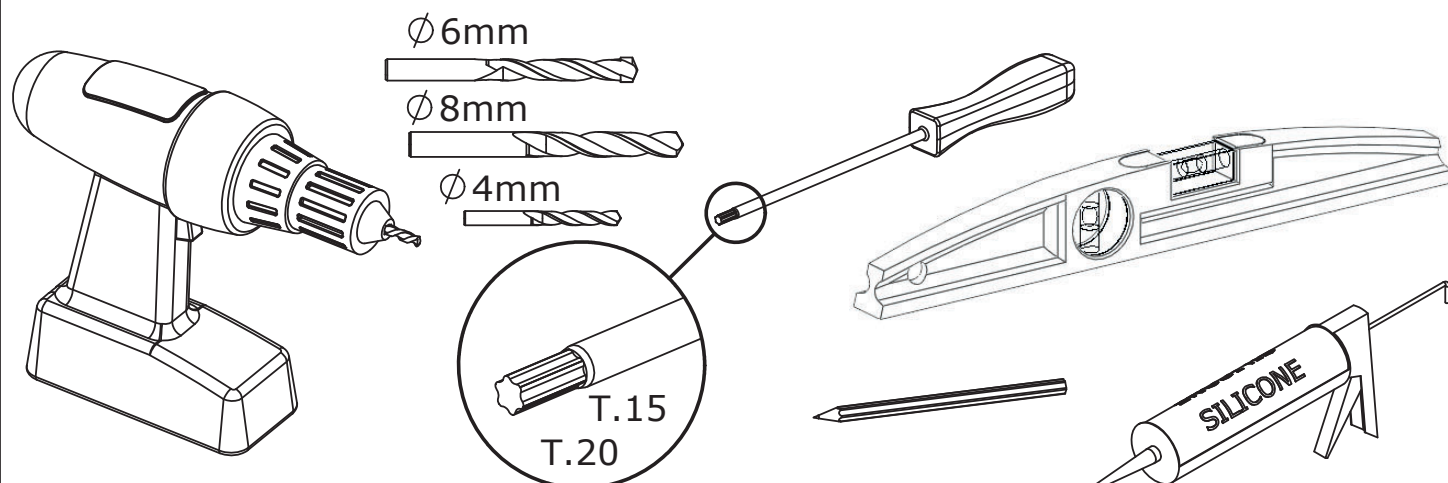

Utiliser un silicone adapté au matériau de chaque support (faïence, acrylique, etc.)

Use a silicone sealant that is intended for the surrounding materials (ceramic, acrylic, etc)

Usar una silicona adecuada para cada tipo de material (loza, acrílico, etc.)

Utilizar um silicone adequado para cada tipo de material (terracota, acrílico, etc.).

Utilizzare un silicone adatto a qualsiasi materiale (ceramica, acrilico ecc.)

Gebruik een silicone die geschikt is voor het materiaal (wandtegels, acryl,...)

Verwenden Sie ein Silikon, das auf das Material des jeweiligen Trägers abgestimmt ist (Steingut, Acryl etc.)

**Fourni dans la boîte d'accessoires - Supplied in the accessory box
 Se suministra en la caja de accesorios - Fornecido em caixa de acessórios
 Fornito nella scatola degli accesri - Meegeleverd in de verpakking -
 Im Zubehörset entalten**

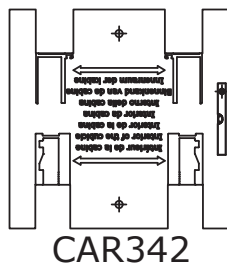

REVERSIBILITE - REVERSIBILITY - REVERSIBILIDAD - REVERSIBILIDADE
 REVERSIBILITA - OMKEERBAARHEID - WAHLWEISE MONTAGE

MONTAGE A GAUCHE
 LEFT HAND
 MONTAJE A LA IZQUIERDA
 MONTAGEM A ESQUERDA
 MONTAGGIO A SINISTRA
 MONTAGE LINKS
 MONTAGE LINKS

MONTAGE A DROITE
 RIGHT HAND
 MONTAJE A LA DERECHA
 MONTAGEM A DIREITA
 MONTAGGIO A DESTRA
 MONTAGE RECHTS
 MONTAGE RECHTS

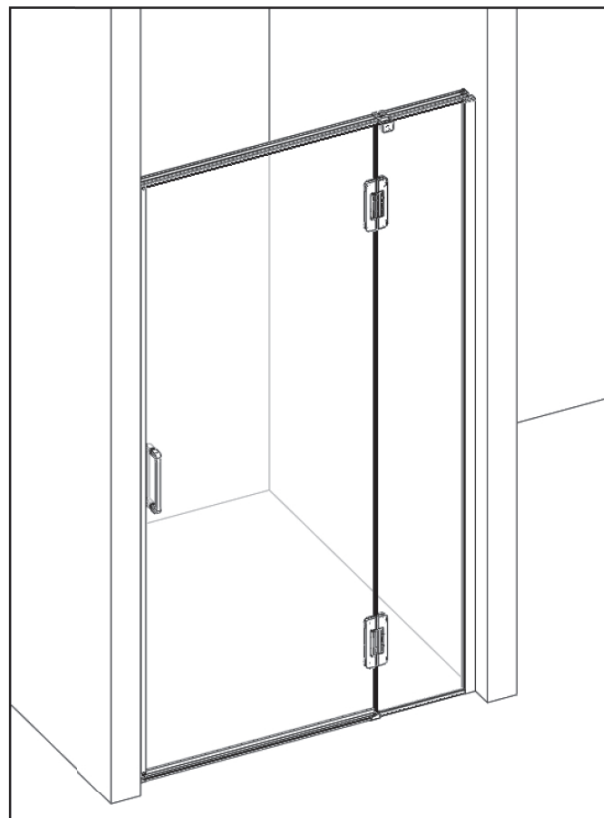
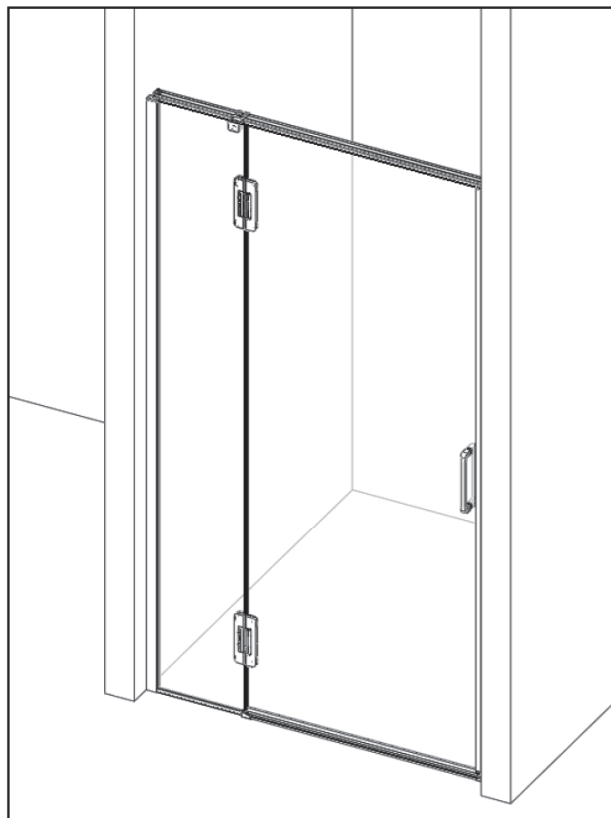

- Vous avez la possibilité de réaliser un montage à droite ou un montage à gauche. Notre notice d'installation décrit un montage à gauche. Si vous voulez réaliser un montage à droite, il vous suffit d'inverser le montage.

- This cubicle can be installed either left or right hand. These installation instructions show a left hand installation.

- Puede realizar un montaje a la derecha o un montaje a la izquierda. Nuestro folleto de instalación describe un montaje a la izquierda. Si desea montar su cabina a la derecha sólo tendrá que realizar el montaje al contrario.

- Pode realizar uma instalação à direita ou uma instalação à esquerda. O nosso manual de instalação descreve uma instalação à esquerda. Se pretende realizar uma instalação à direita, basta inverter a instalação.

- Avete la possibilità di effettuare il montaggio a destra o a sinistra. Il nostro manuale descrive il montaggio a sinistra. Se volete realizzare il montaggio a destra è sufficiente invertire varie fasi di montaggio.

- U kunt de douchecabine rechts of links monteren. Onze handleiding beschrijft de links montage van de cabine. Keer de montage om als u de cabine rechts wilt monteren.

- Sie haben die Möglichkeit, eine Montage auf der linken Seite oder eine Montage auf der rechten Seite durchzuführen. Unsere Montageanleitung beschreibt eine Montage auf der linken Seite. Wenn Sie die Montage lieber auf der rechten Seite durchführen wollen, müssen Sie nur den Montageprozess umkehren.

Intérieur - Inside
 Interior - Interior - Interno
 Binnenkant - Innen

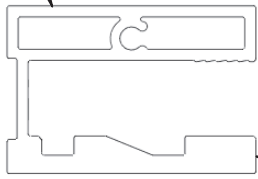

C

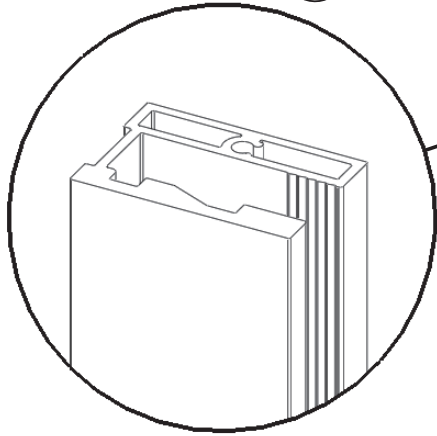

Si receveur - If shower tray
 Si plato - Se recetor - Se piatto
 Als douchebak - Wenn Duschwanne

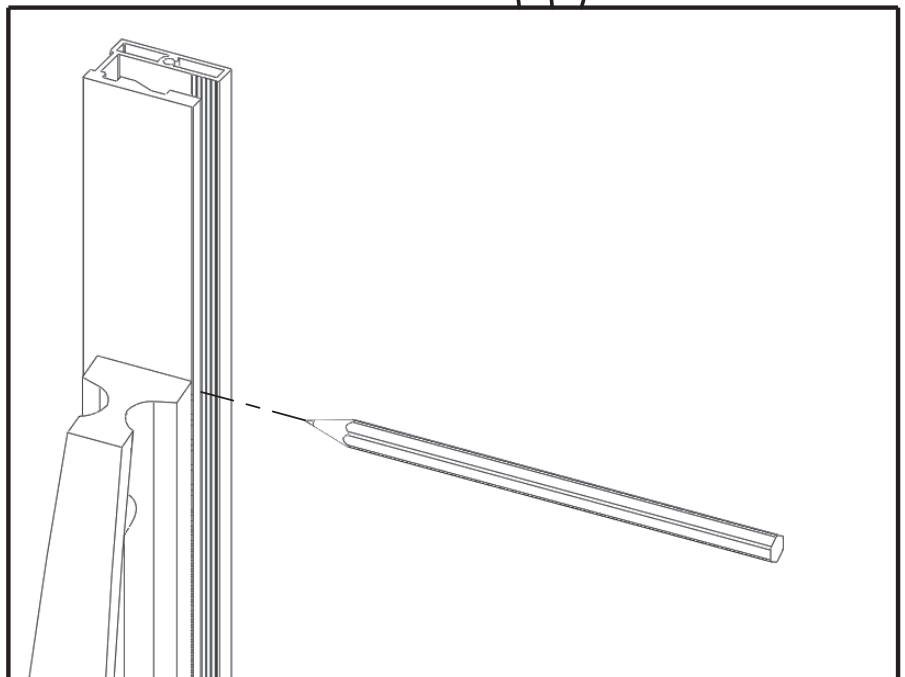
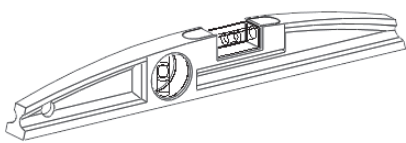
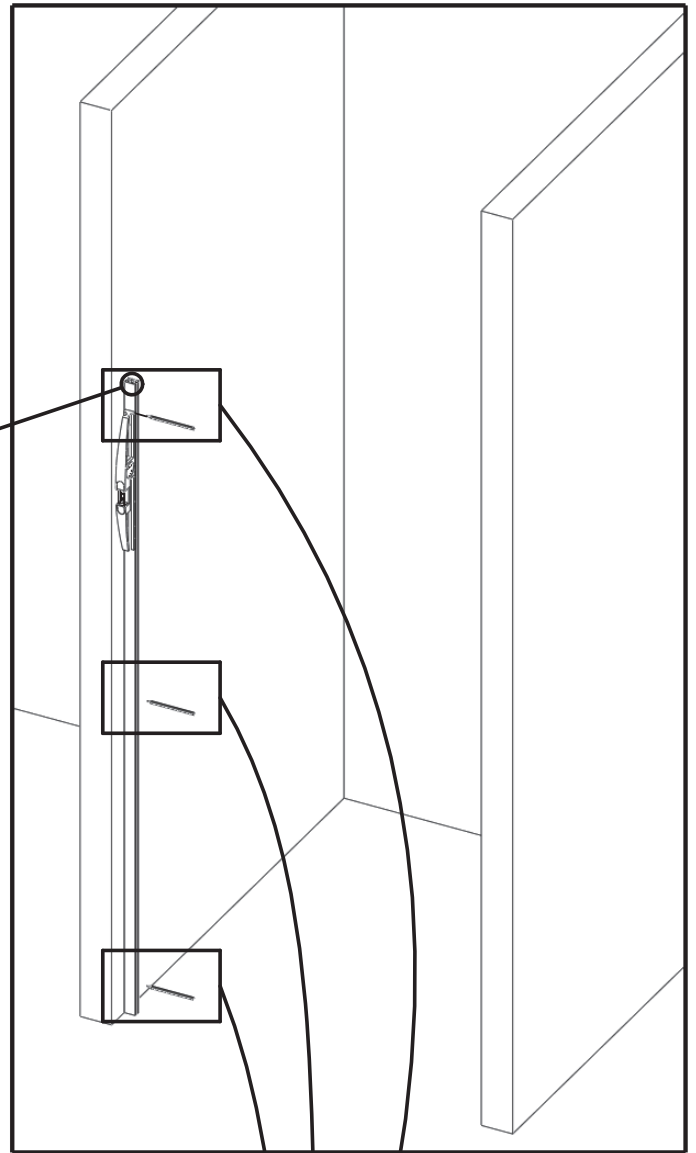
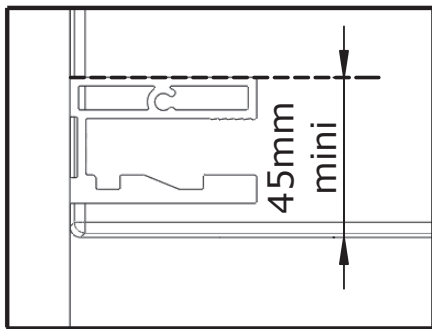

Intérieur - Inside
Interior - Interior - Interno
Binnenkant - Innen

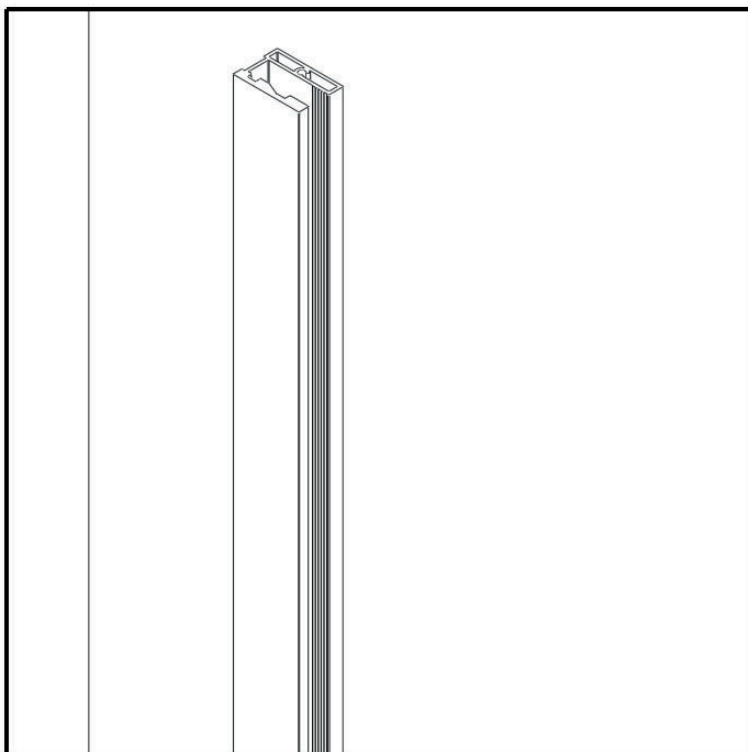
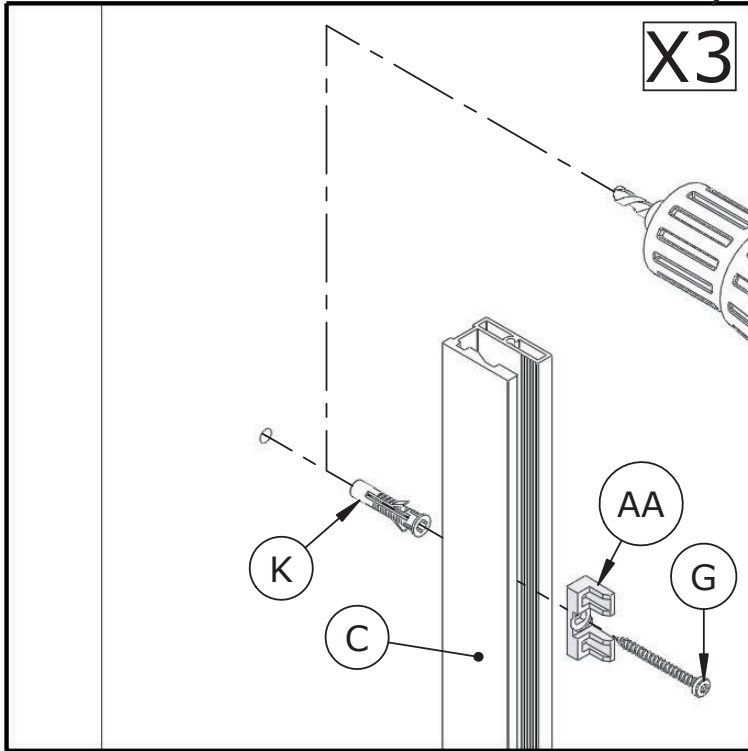
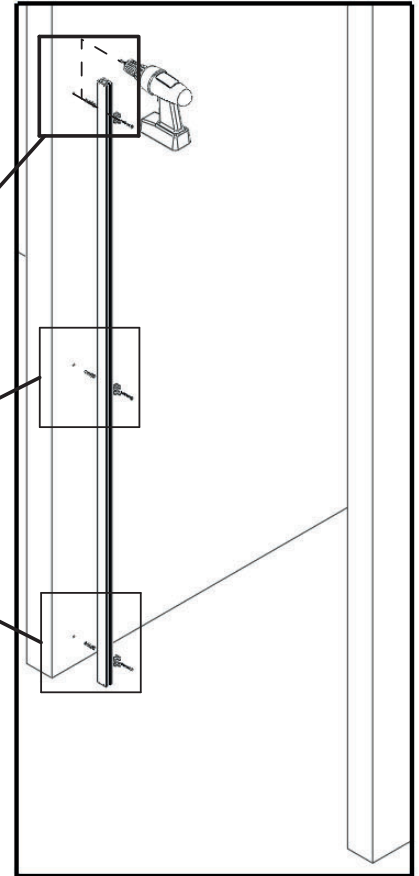
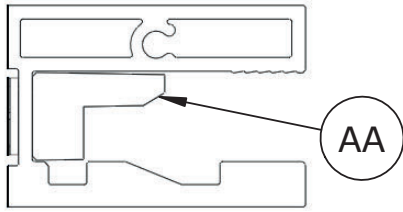

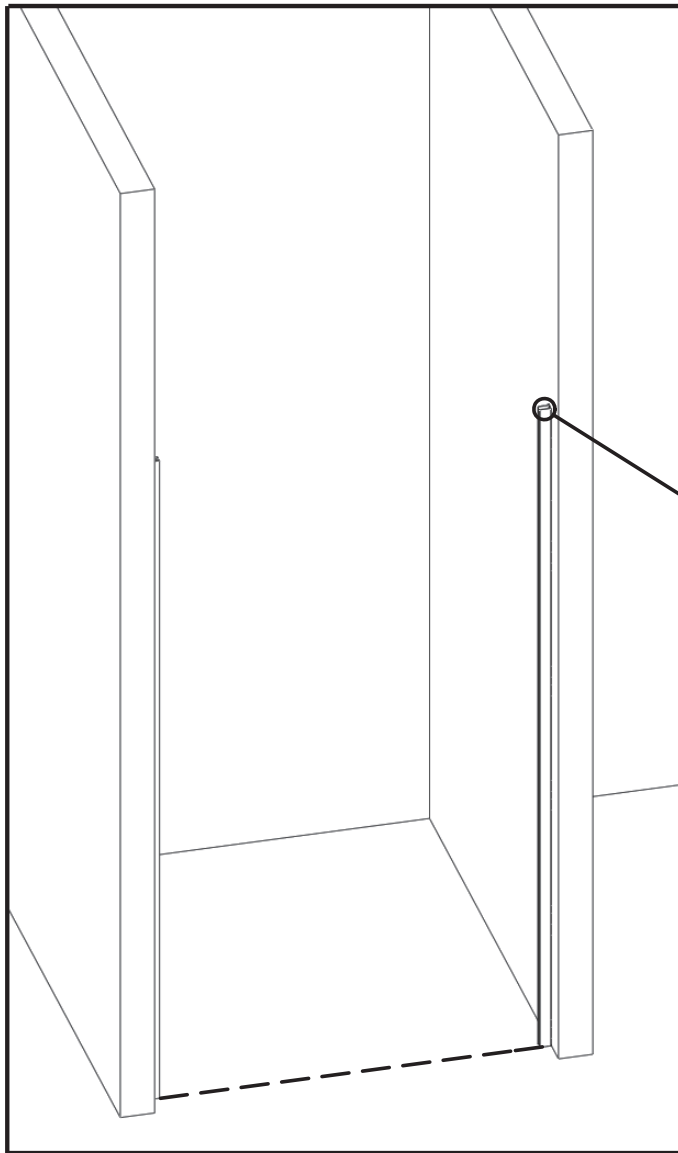

Intérieur - Inside
 Interior - Interior - Interno
 Binnenkant - Innen

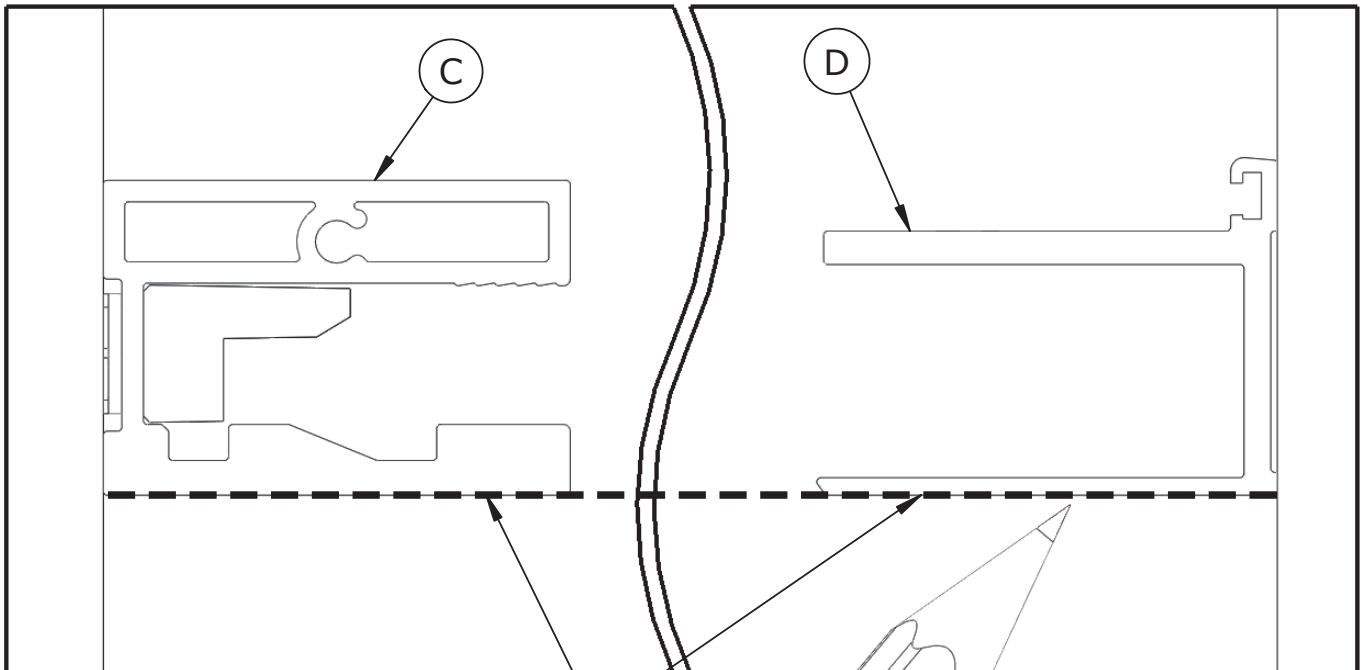
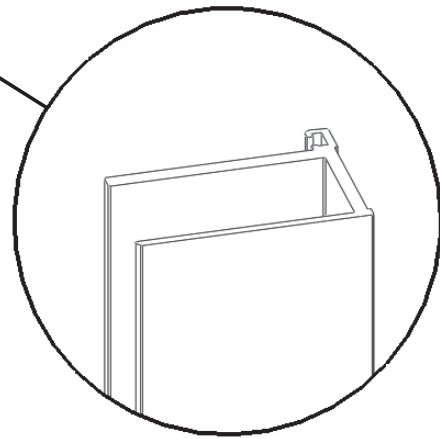
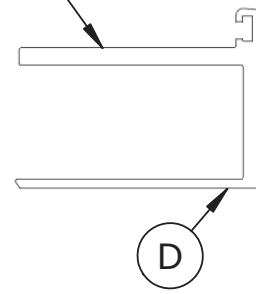

Alignement - Alignment
 Alineación - Alinhamento - Allineamento
 Uitlijning - Verlängerung

Intérieur - Inside
Interior - Interior - Interno
Binnenkant - Innen

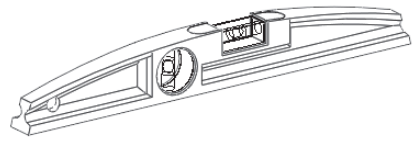
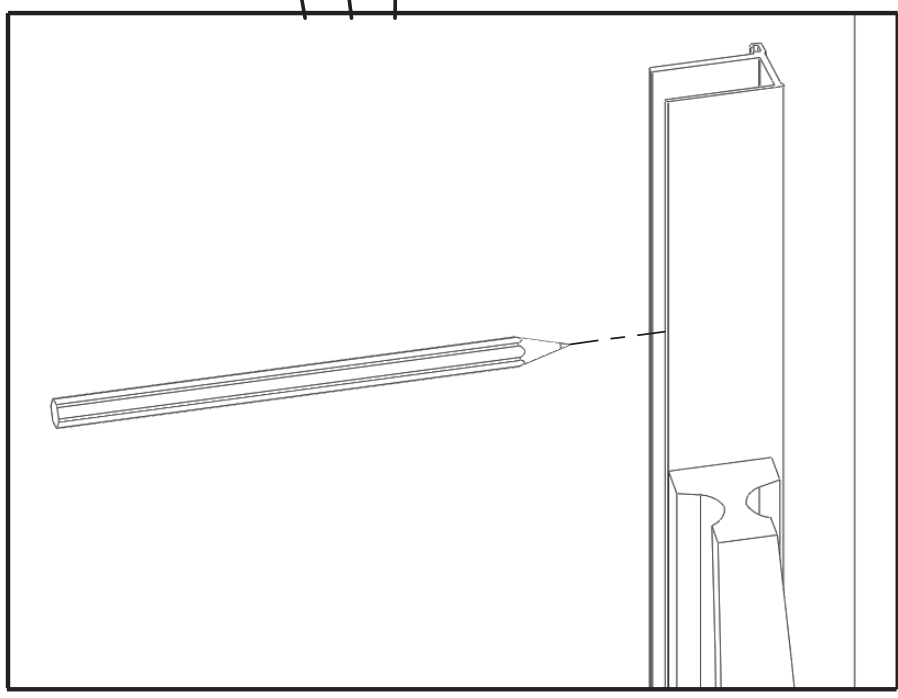
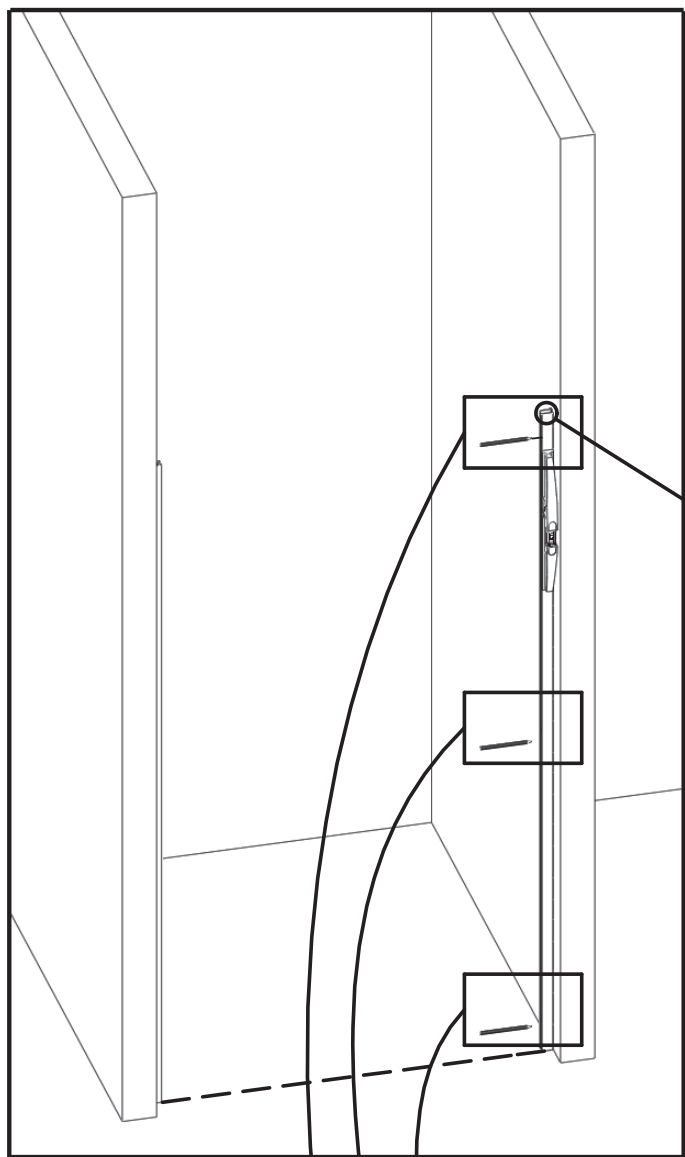
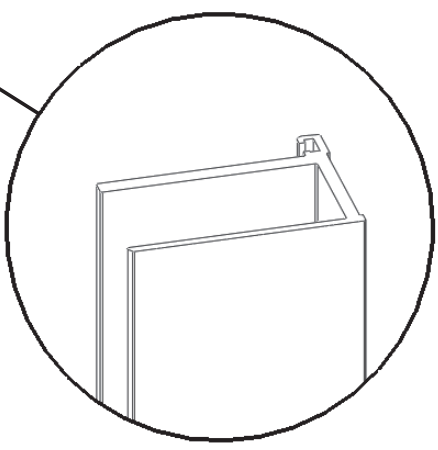
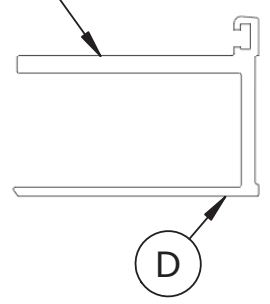

Intérieur - Inside
Interior - Interior - Interno
Binnenkant - Innen

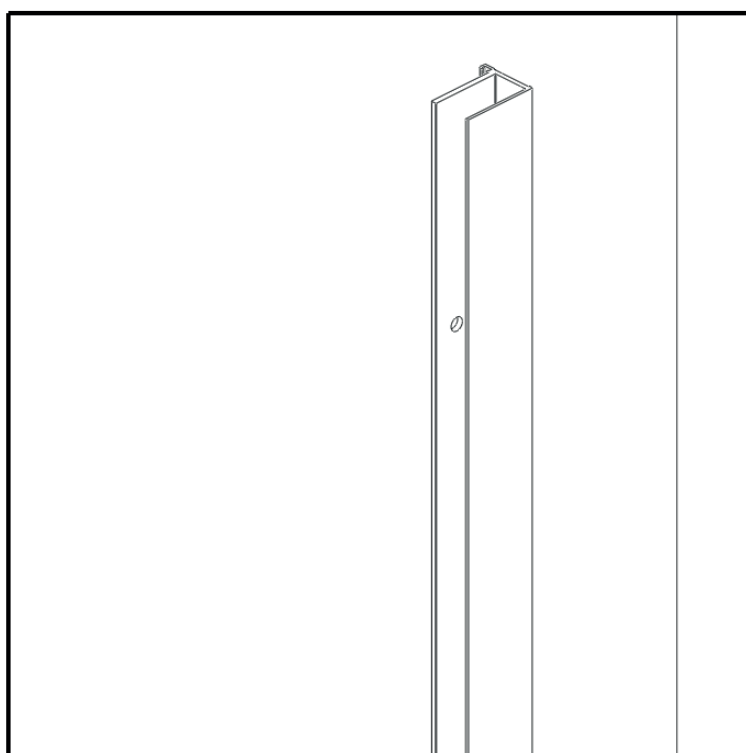
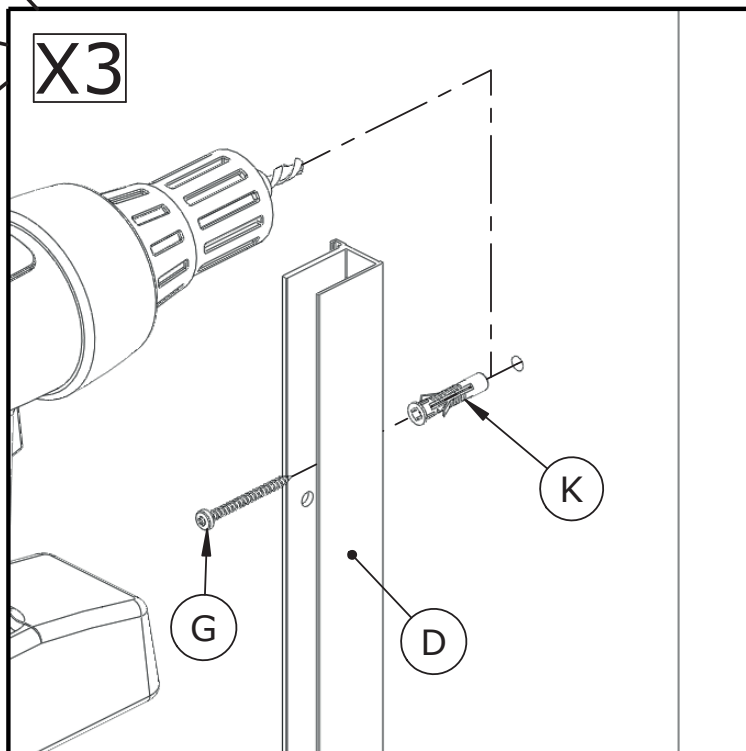
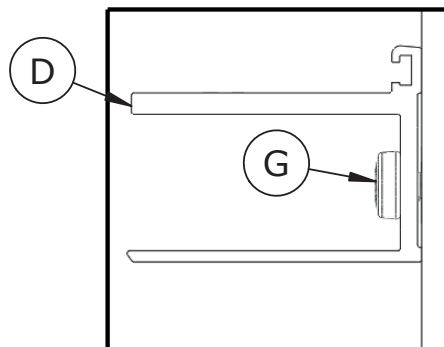
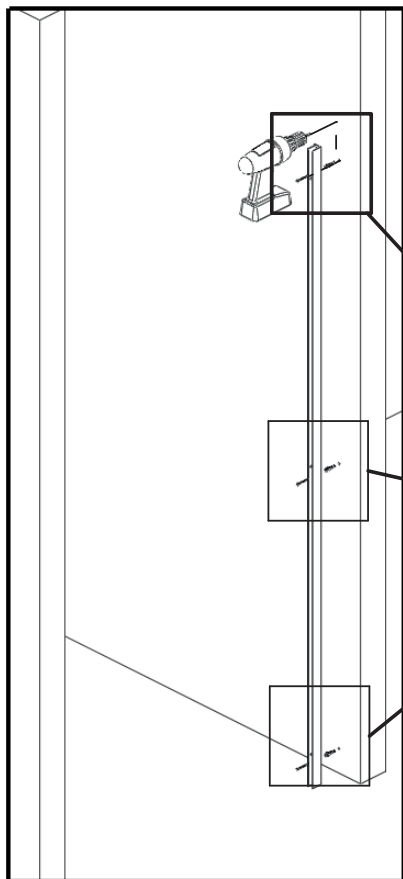

Intérieur - Inside
Interior - Interior - Interno
Binnenkant - Innen

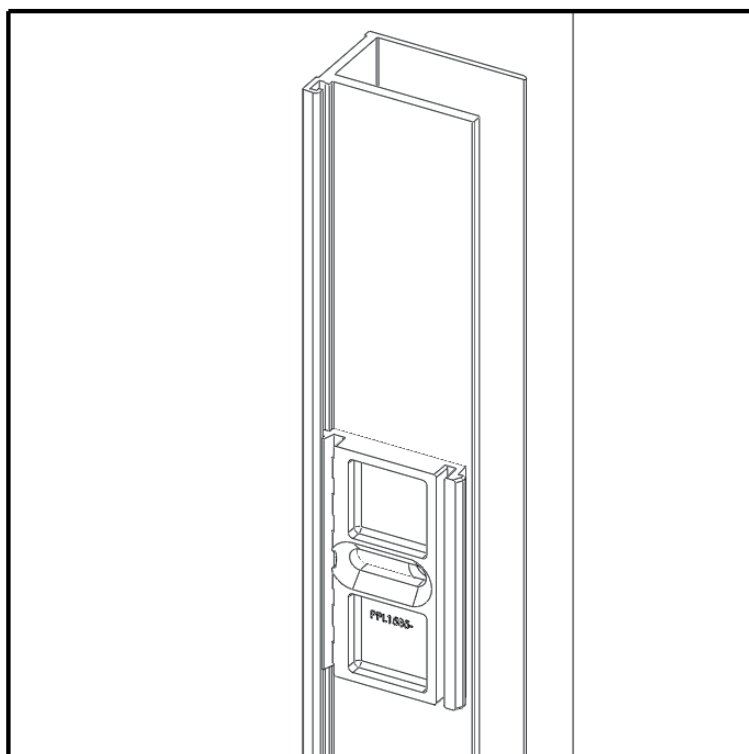
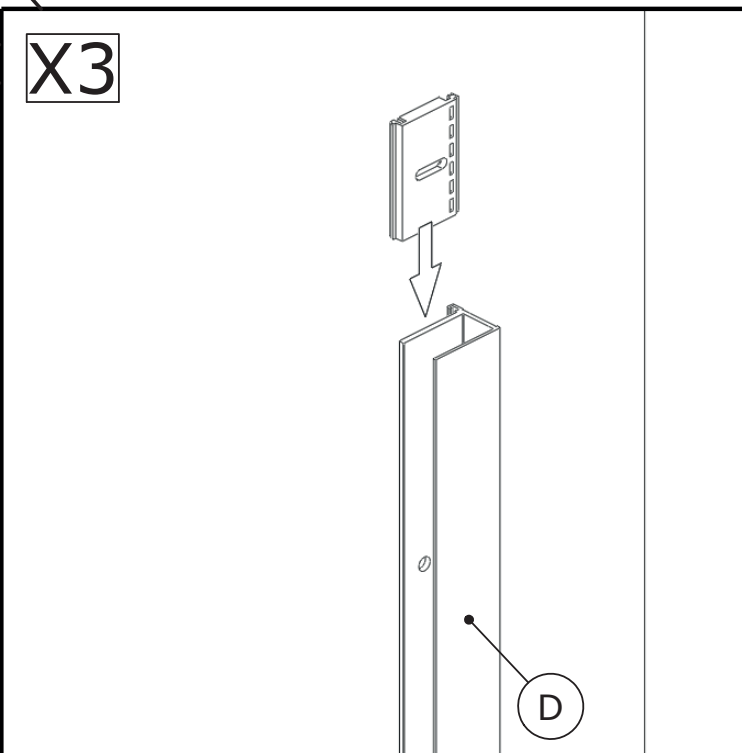
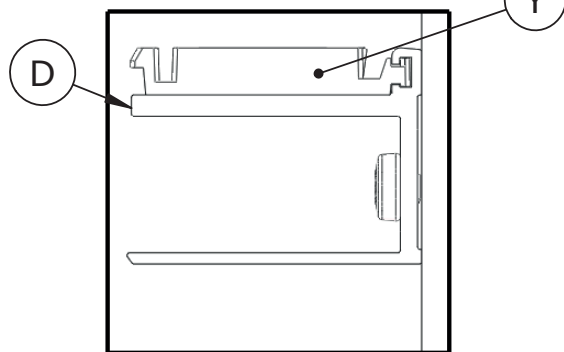
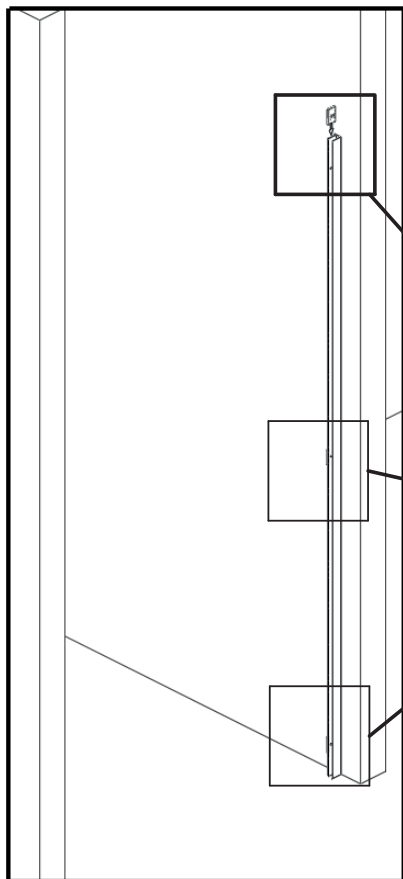

Intérieur - Inside
Interior - Interior - Interno
Binnenkant - Innen

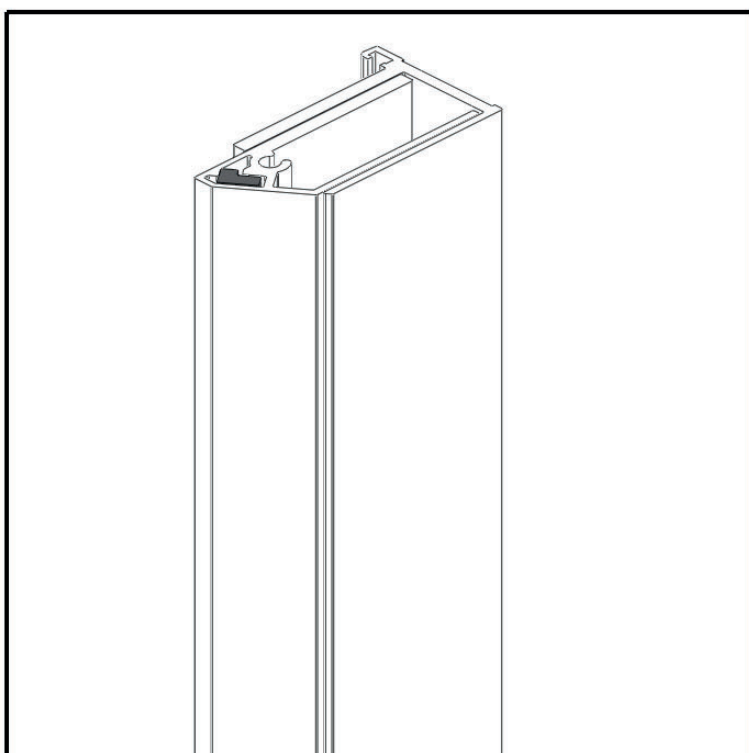
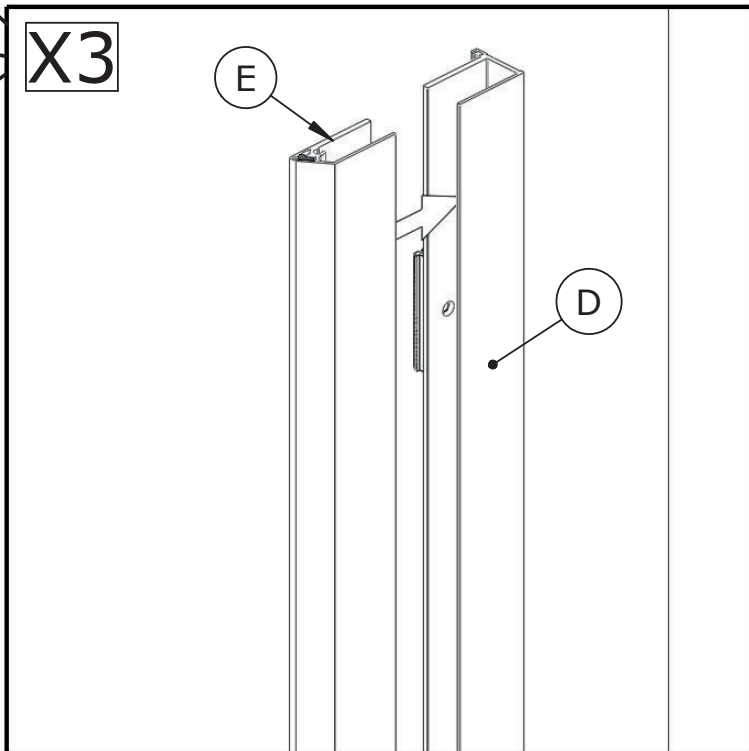
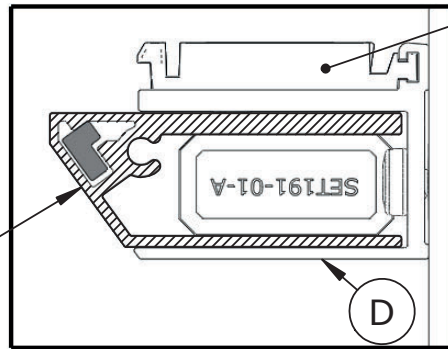
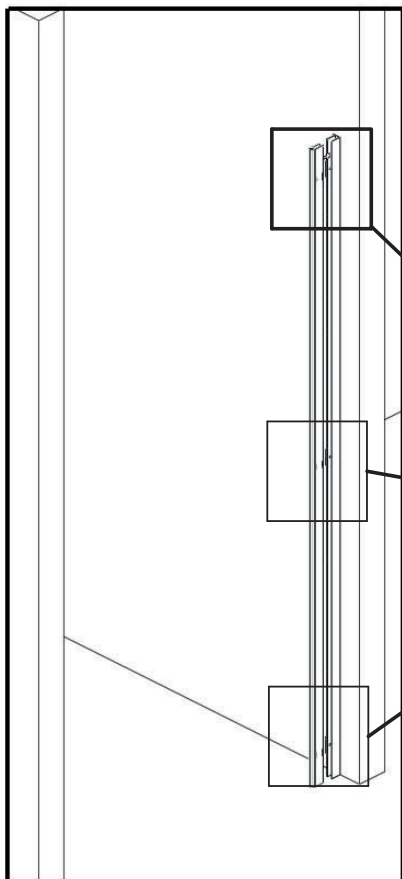

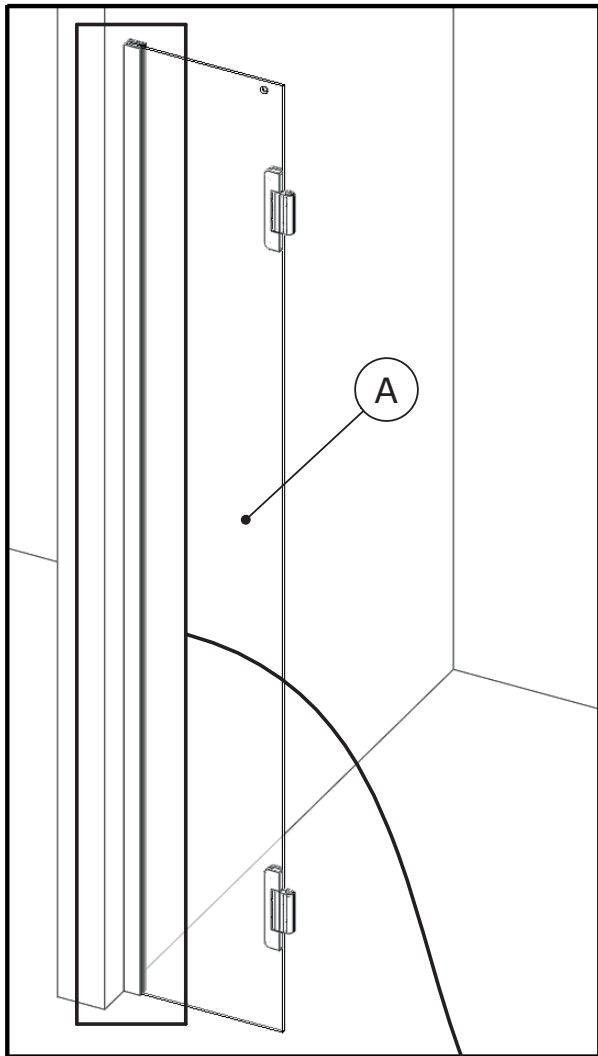

Intérieur - Inside
Interior - Interior - Interno
Binnenkant - Innen

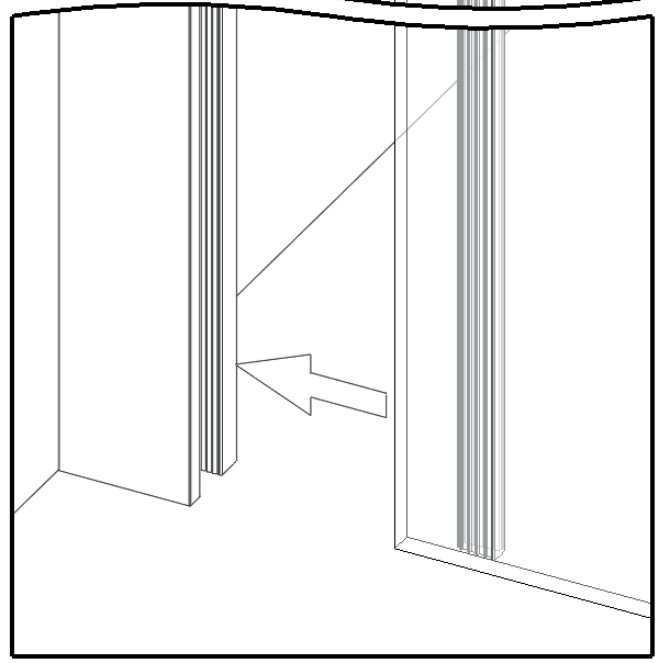
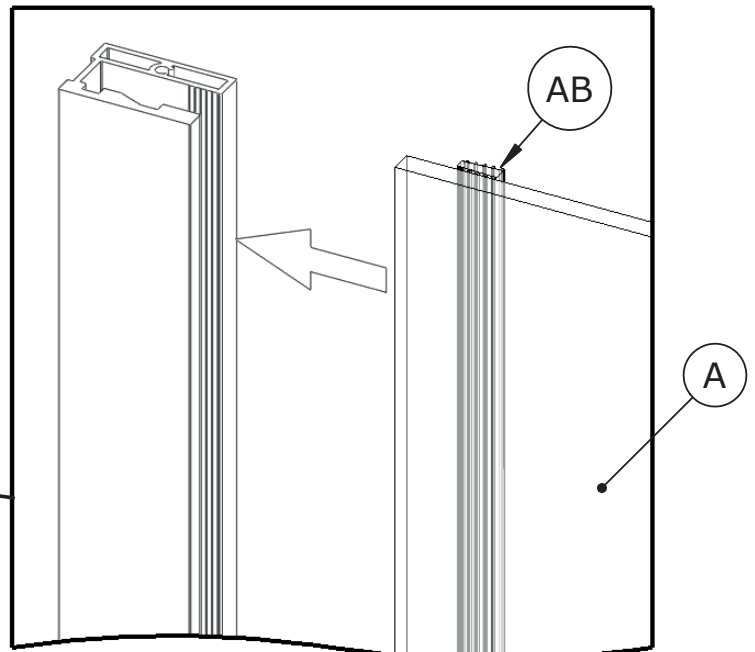
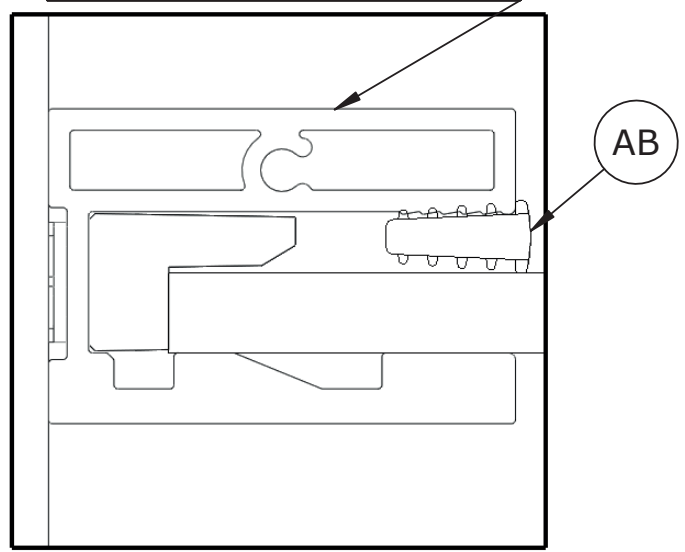

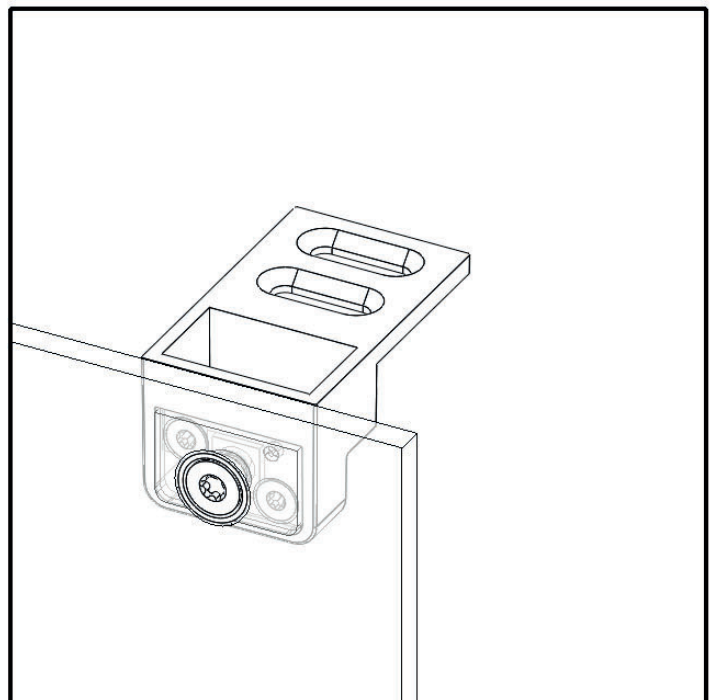
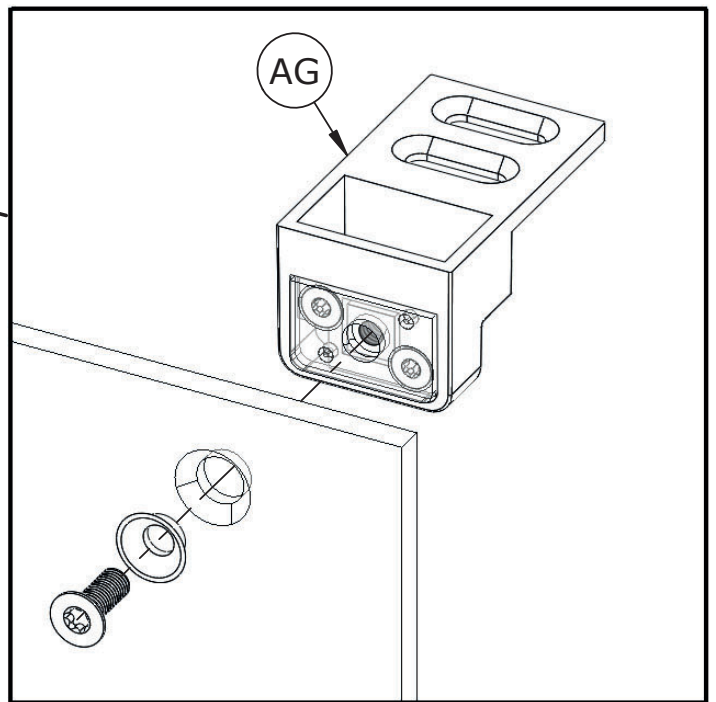
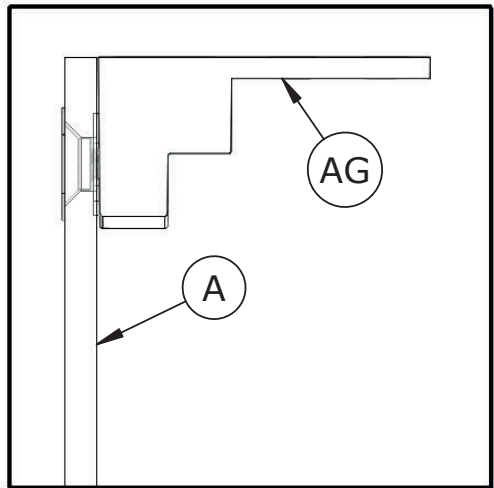
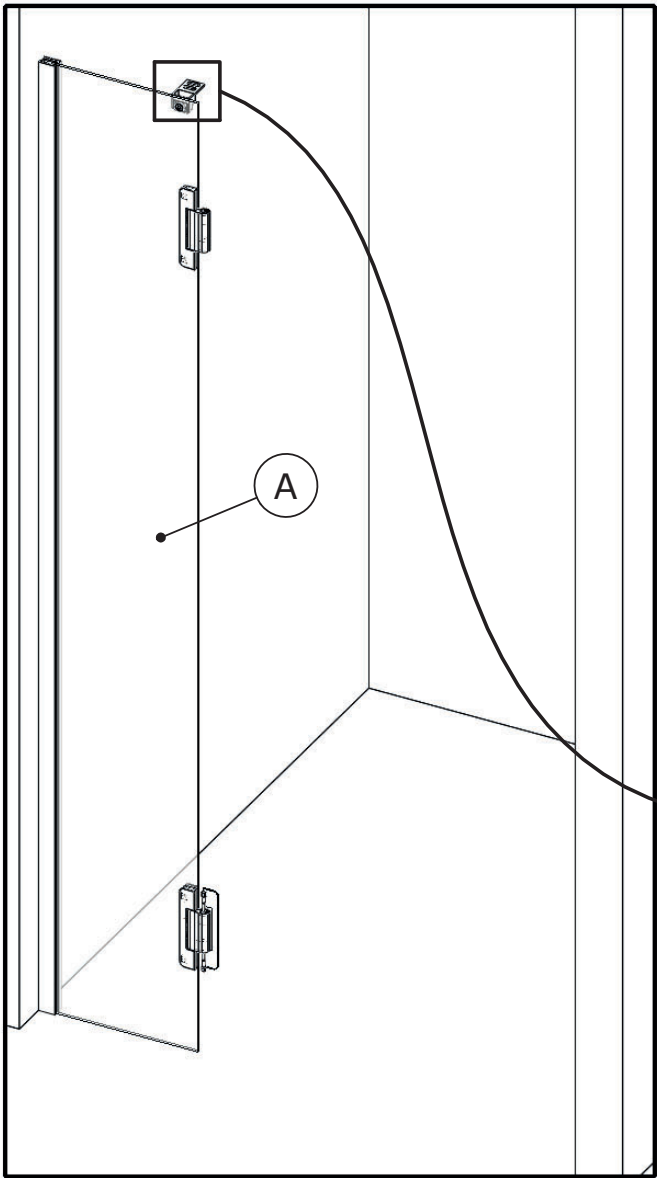

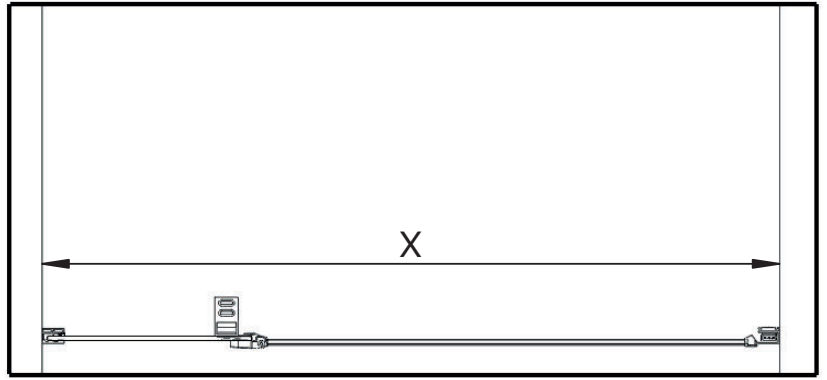
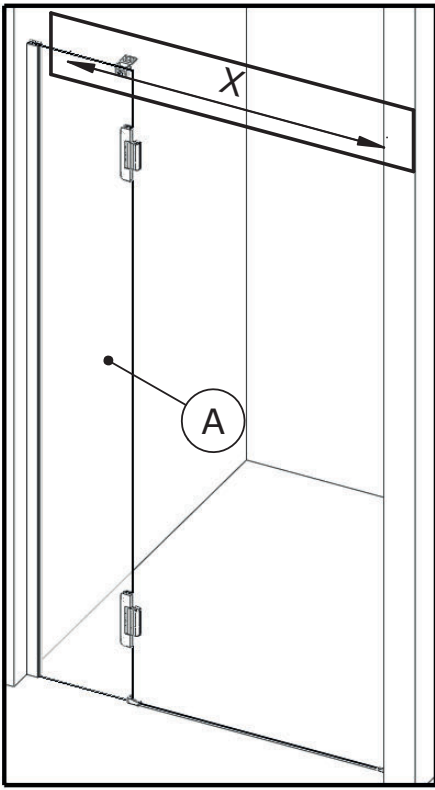

A conserver
 Conserve this part
 A conservar
 A ser retido
 Conservare
 Bewaren
 Aufbewahren

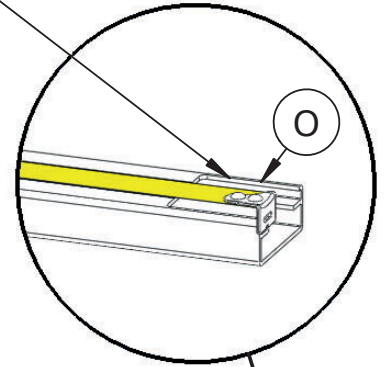

1

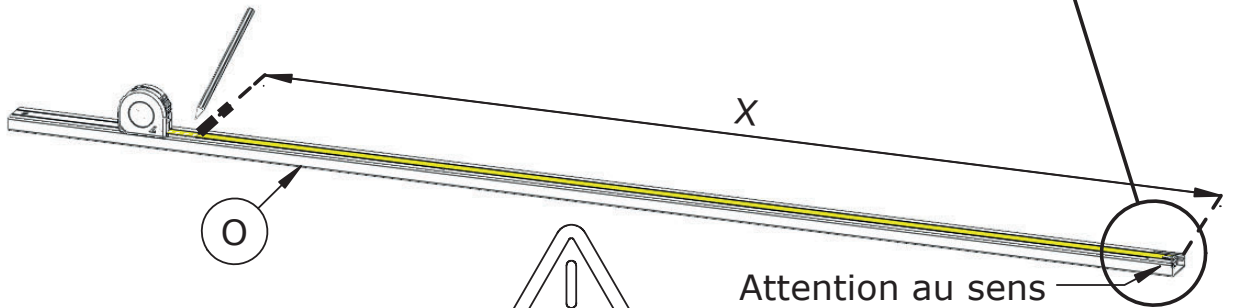

Attention au sens
 Attention to the direction
 Atención al significado
 Atenção ao significado
 Attenzione al significato
 Let op de richting
 X Richtung beachten

2

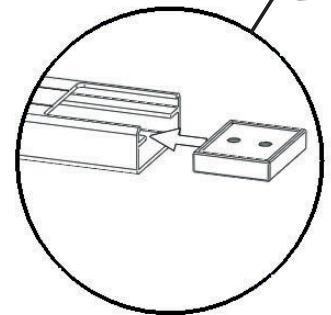
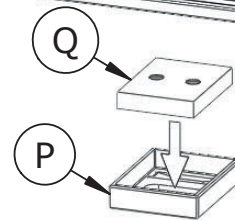
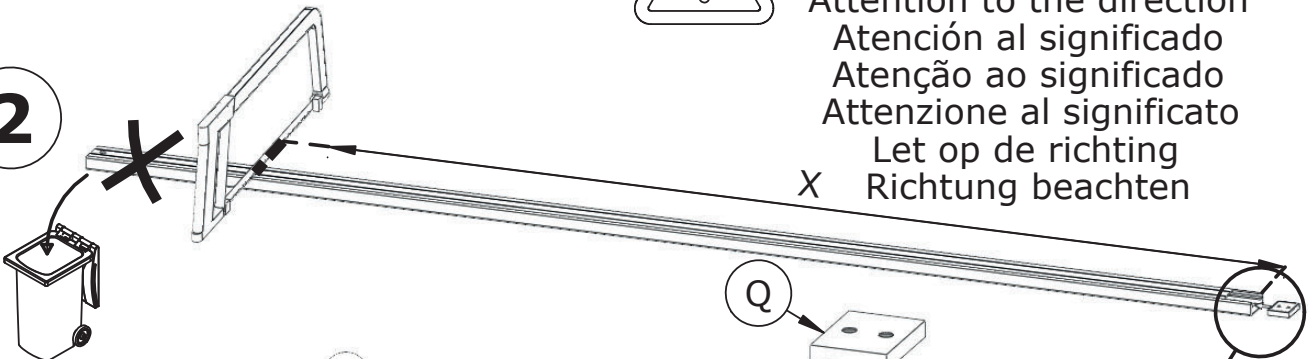

3

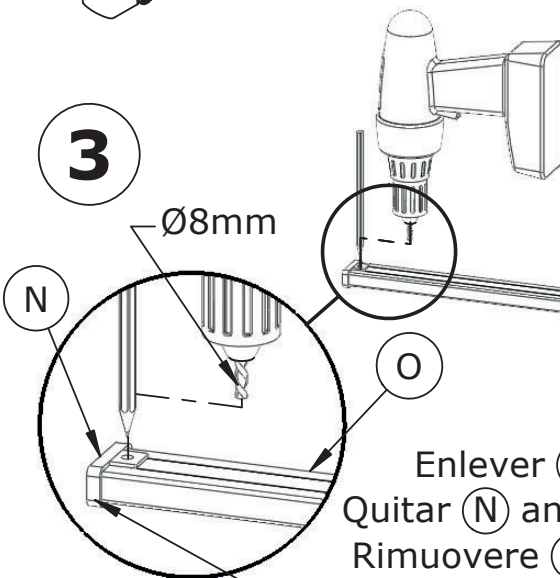

Enlever (N) avant de percer - Remove (N) before drilling
 Quitar (N) antes de perforar - Retirar (N) antes da perfuração -
 Rimuovere (N) prima di forare - Verwijder (N) voor het boren -
 (N) vor dem Bohren entfernen

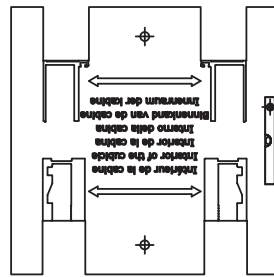
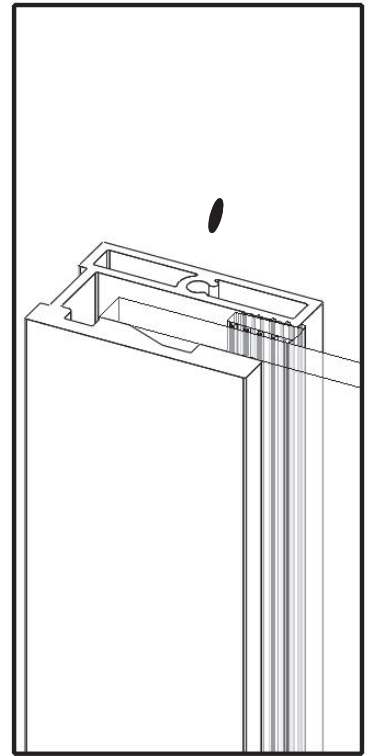
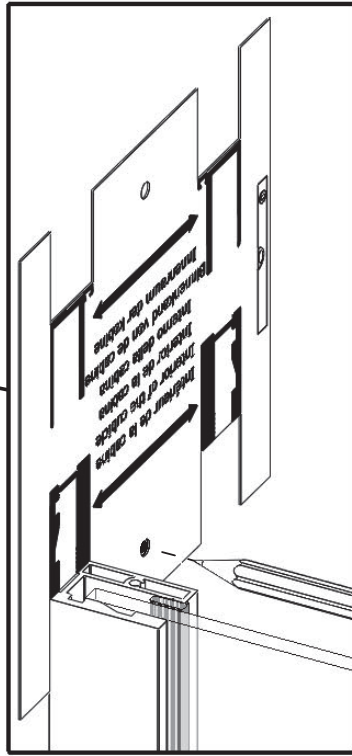
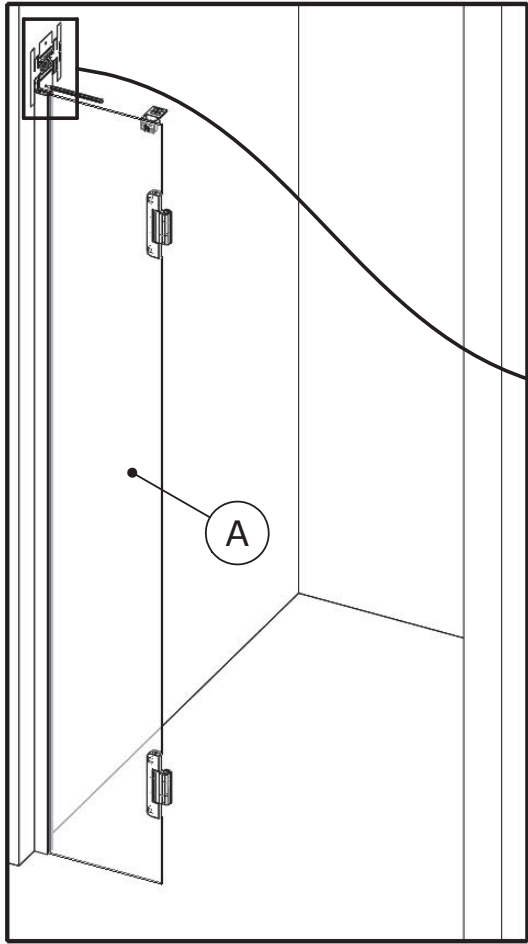

CAR342

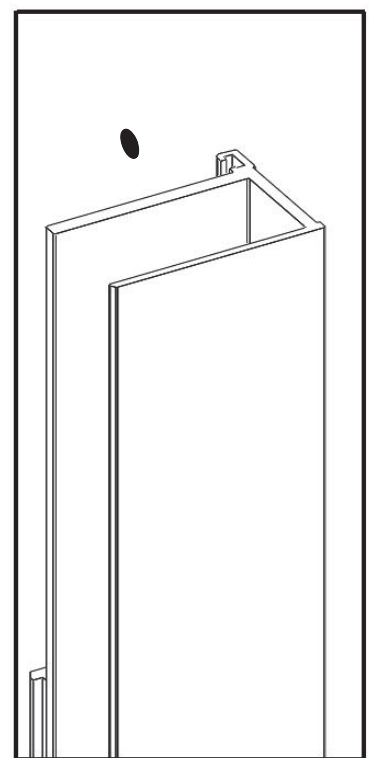
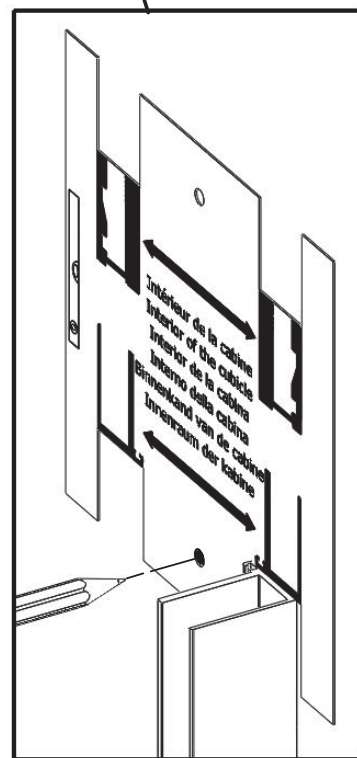
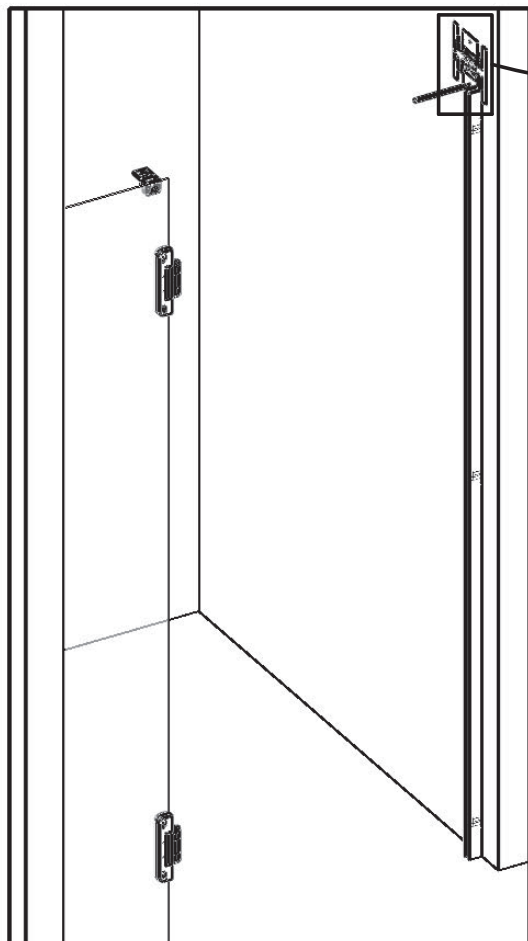

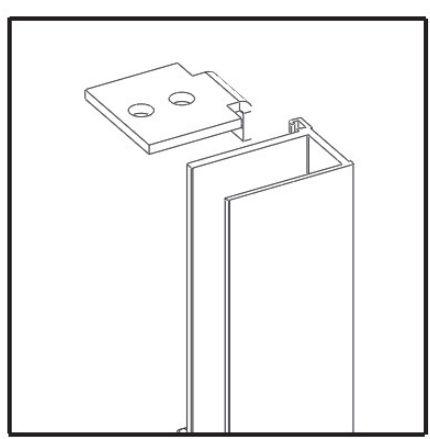
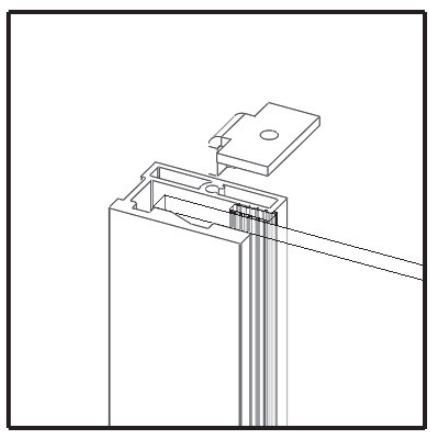
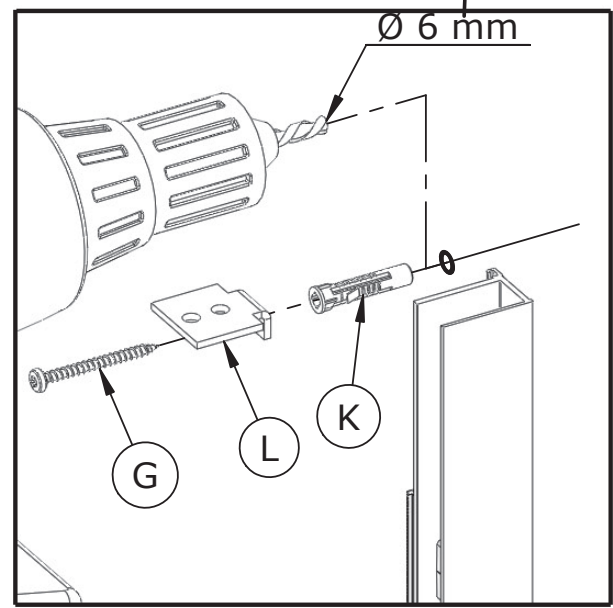
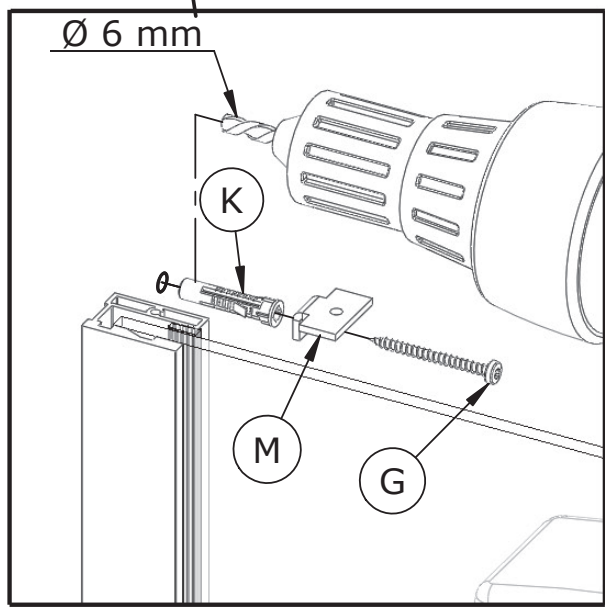
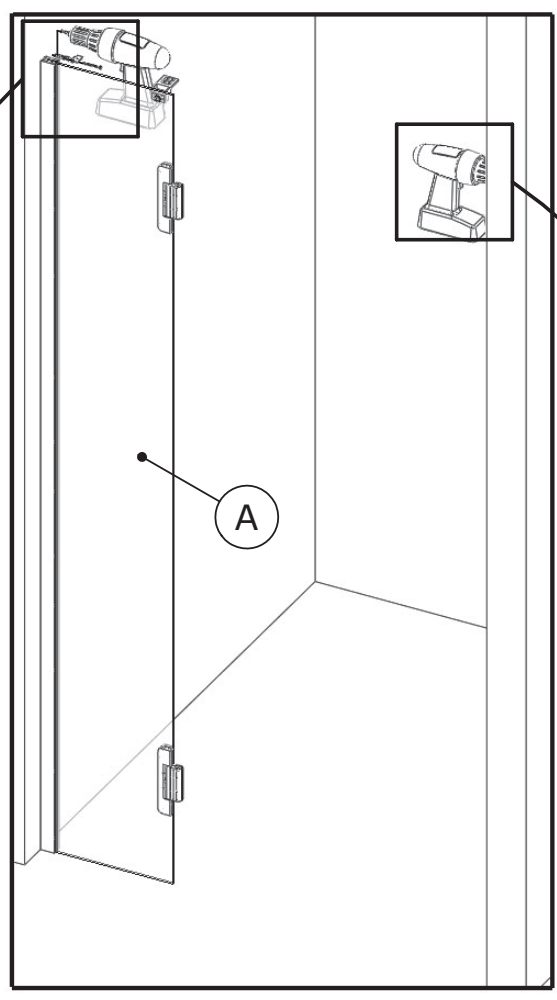

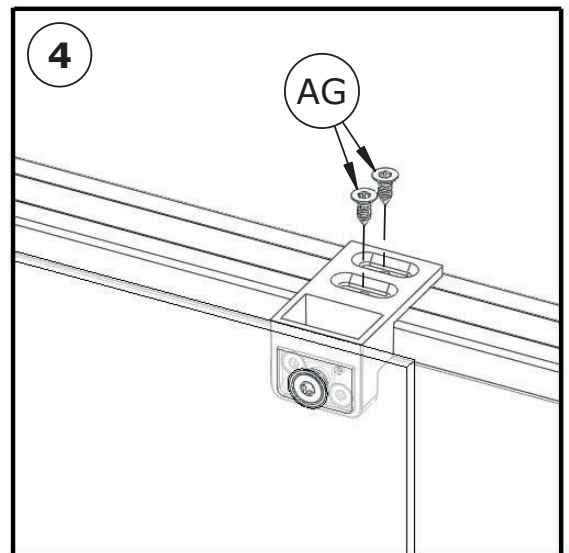
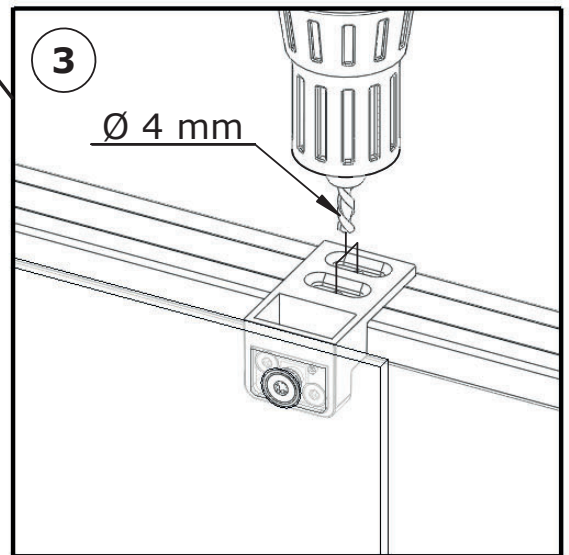
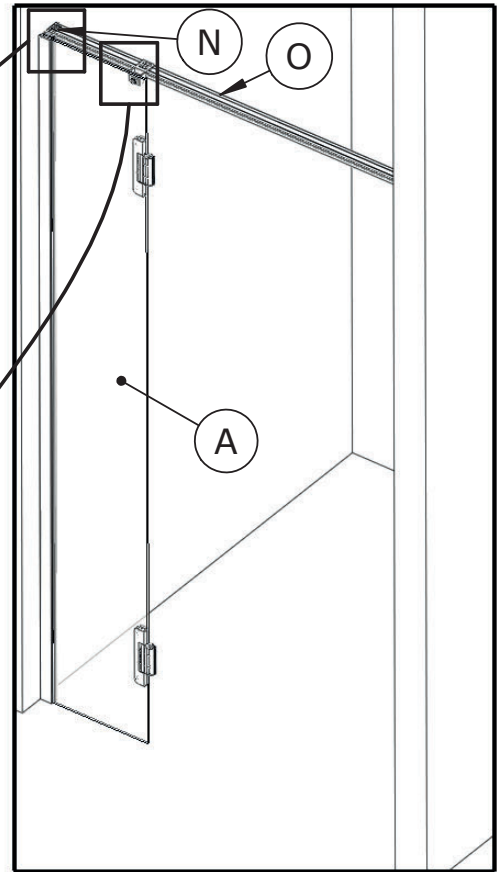
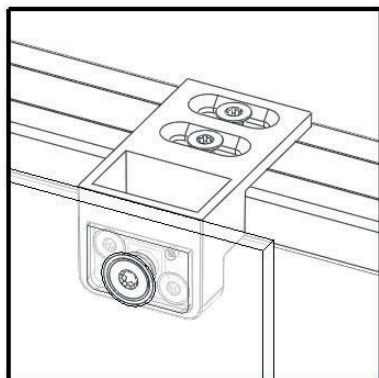
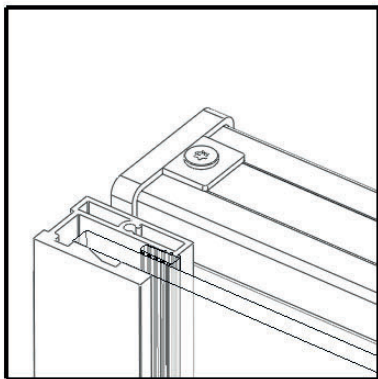
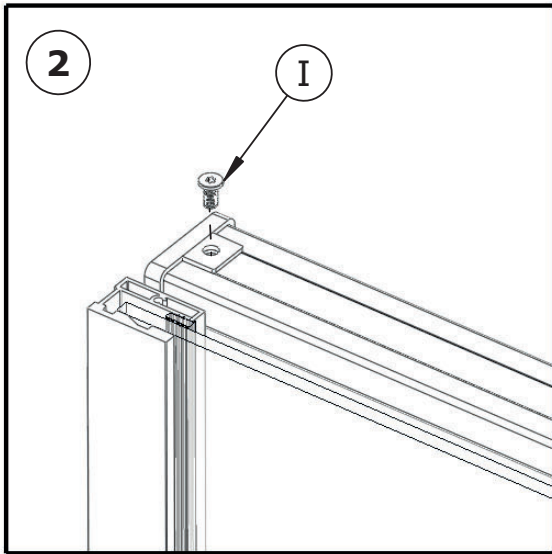
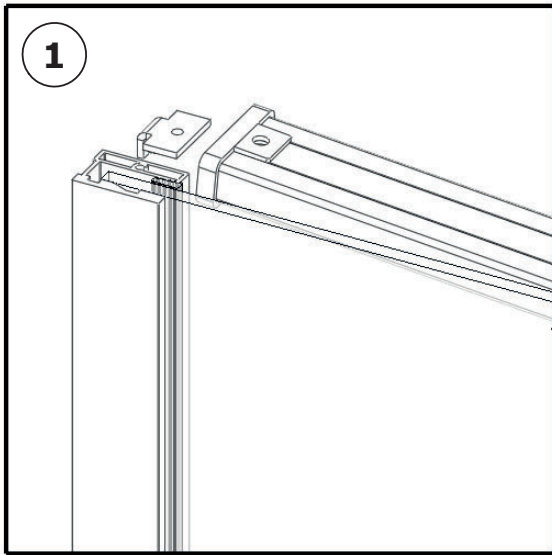

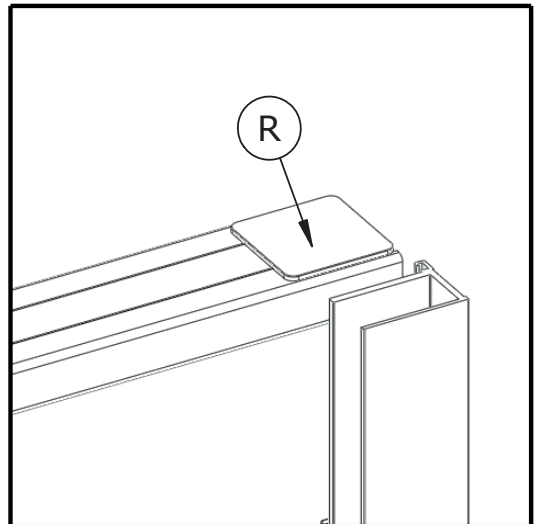
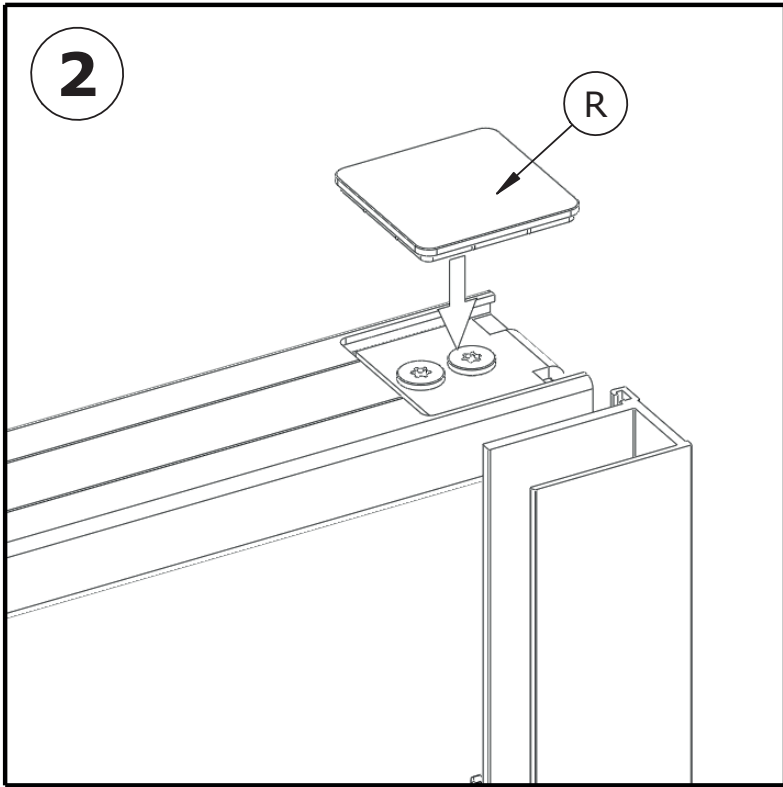
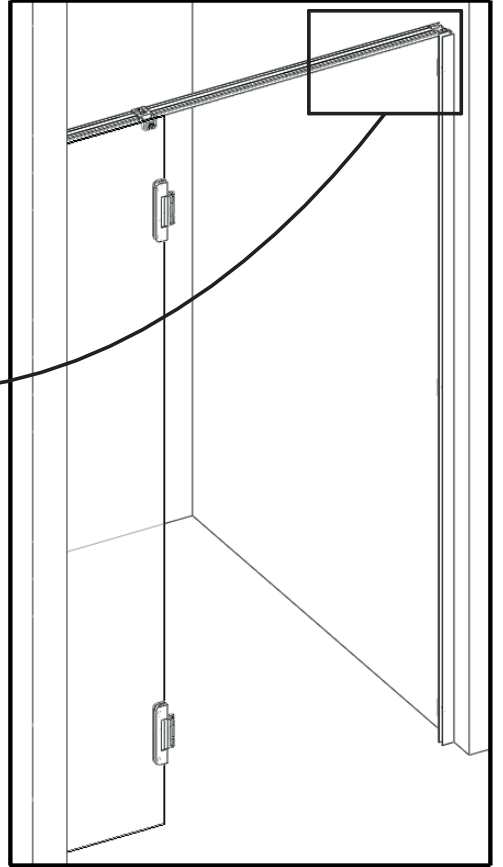
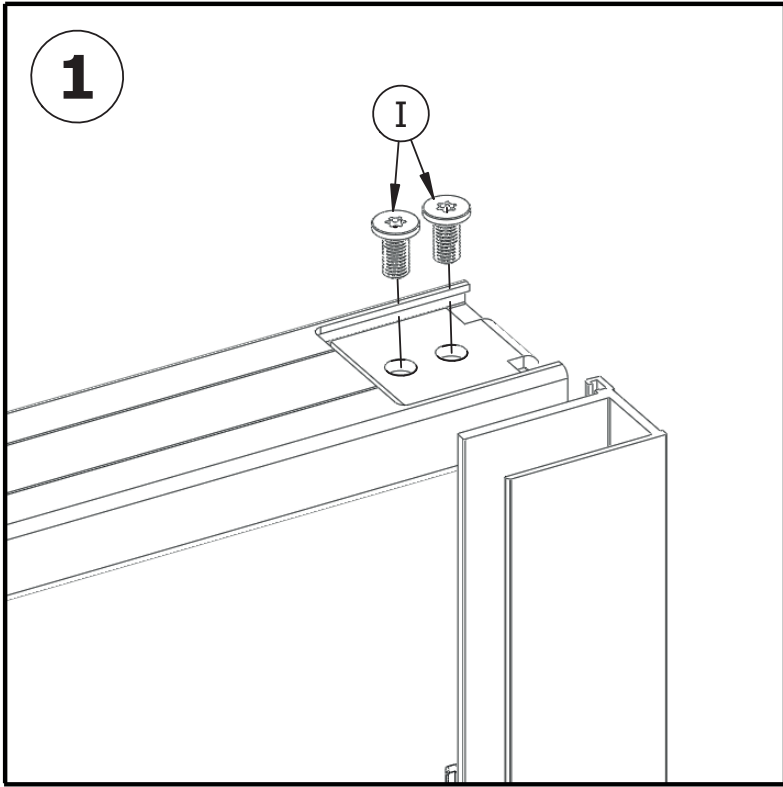

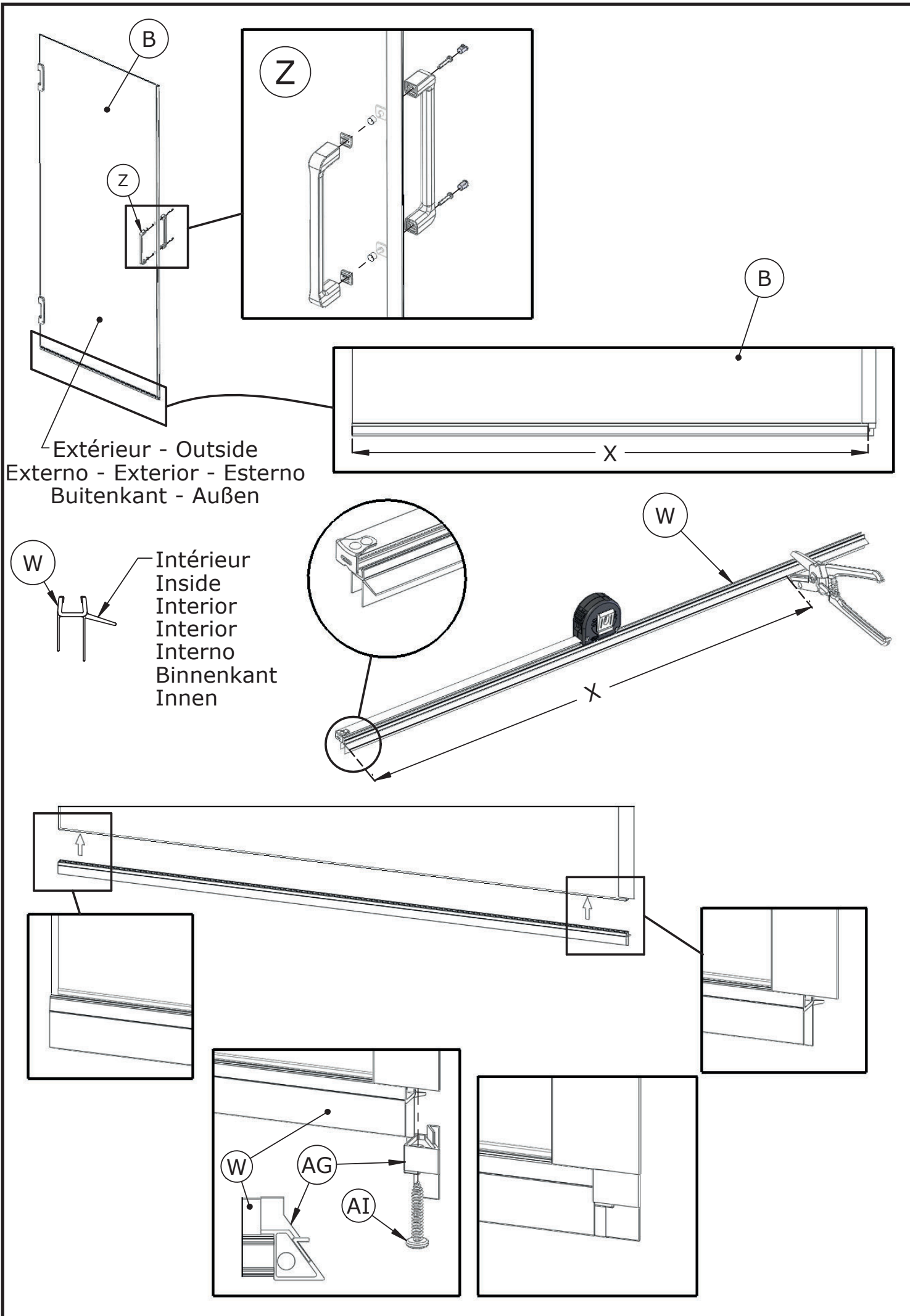

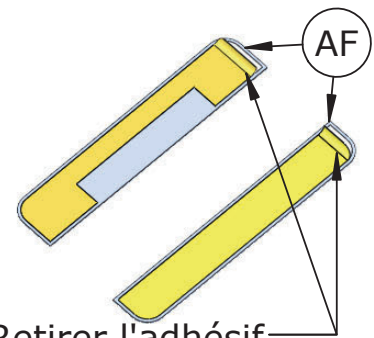
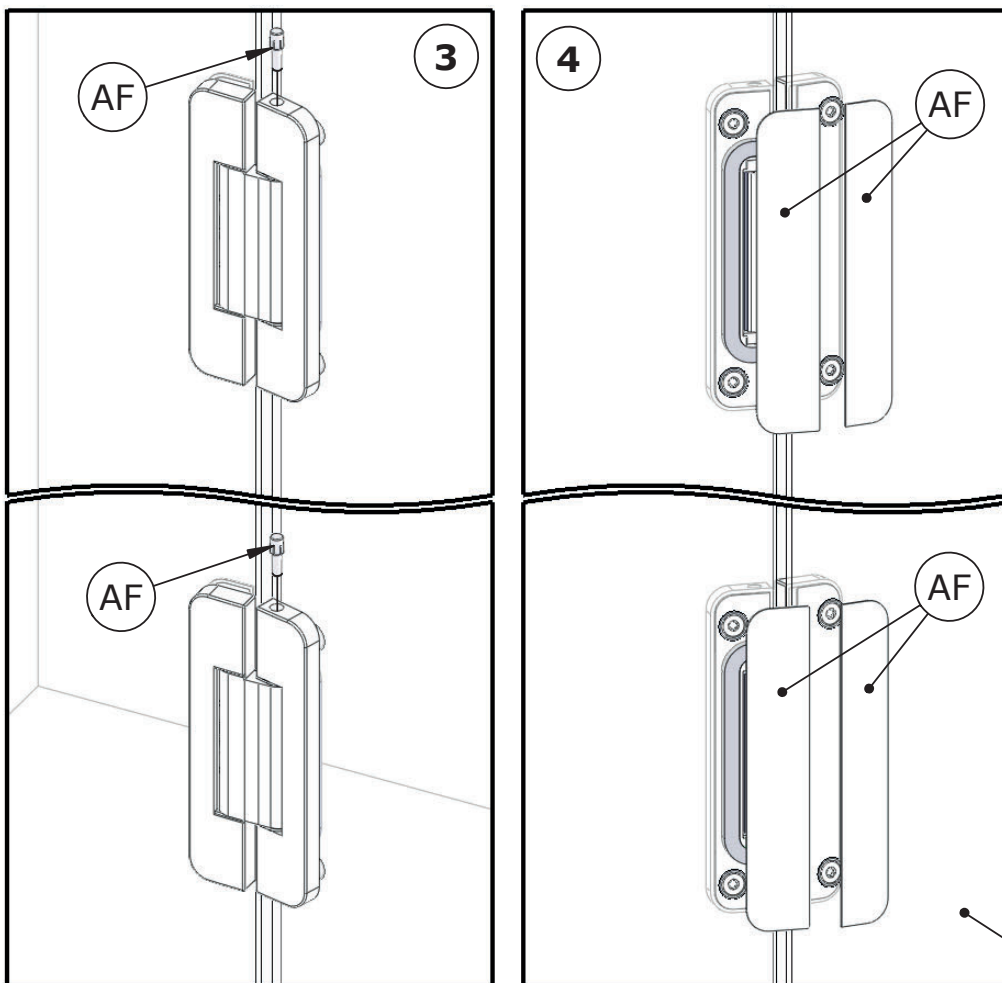
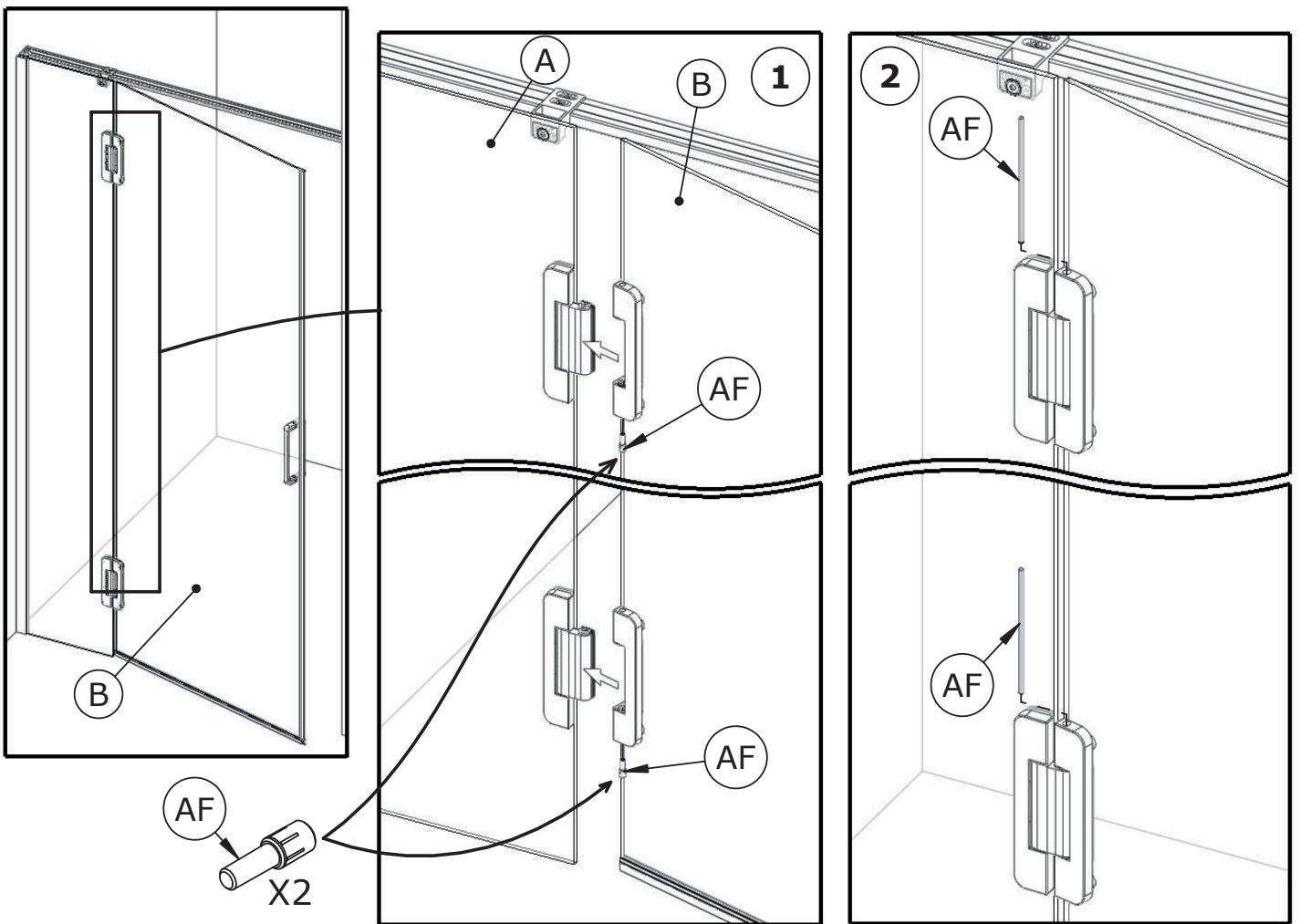

Retirer l'adhésif
 Remove adhesive
 Quitar el adhesivo
 Retire o adesivo
 Rimuovere il adesivo
 Verwijder de lijm
 Klebstoff entfernen

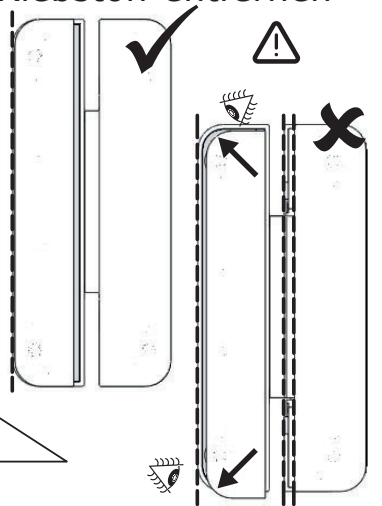

Intérieur - Inside - Interior - Interior
 Interno - Binnenkant - Innen

Réglage de la porte - Door adjustment
 Ajuste de la puerta - Ajuste da porta - Regolazione porta
 Afstellen van de deur - Einstellen der Tür

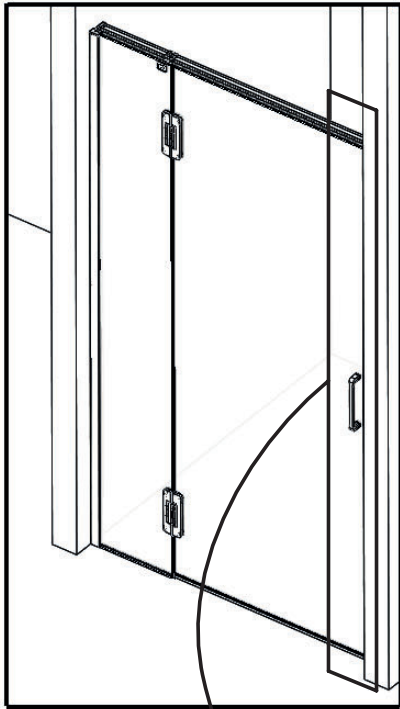

-Régler l'aplomb et l'aimantation, puis serrer.

-Adjust plumbness and magnetization, then tighten.

-Ajustar la plomada y la magnetización, luego apretar.

-Ajuste a linha de prumo e a magnetização, em seguida, apertar.

-Regolare la piombatura e la magnetizzazione, poi stringere

-Stel de pluim en de magnetisatie af, draai dan.

-Stellen Sie das Lot und die Magnetisierung ein, dann ziehen Sie

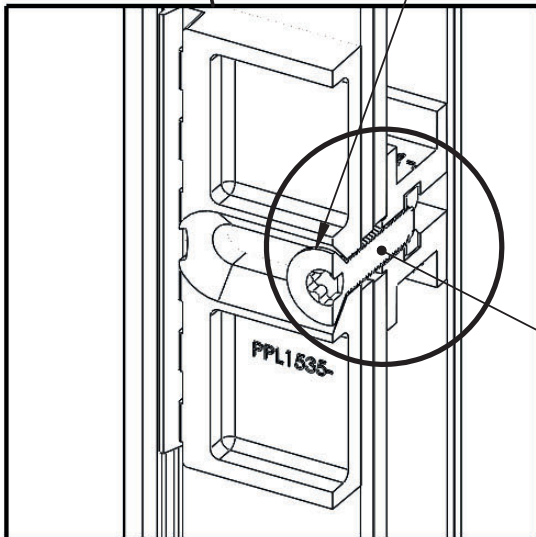

Intérieur - Inside
 Interior - Interior - Interno
 Binnenkant - Innen

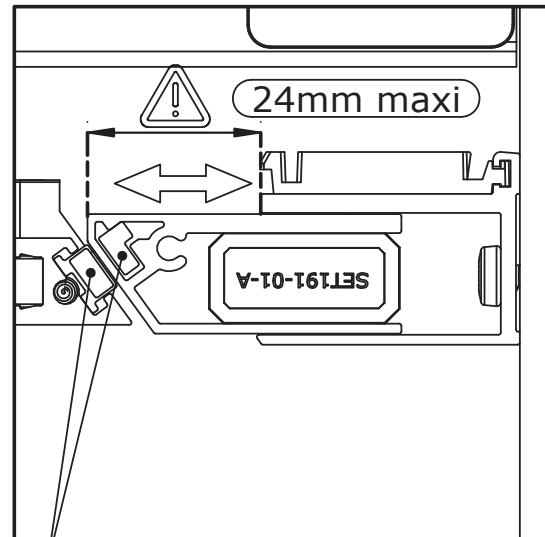

Alignement - Alignment
 Alineación - Alinhamento - Allineamento
 Uitlijning - Verlängerung

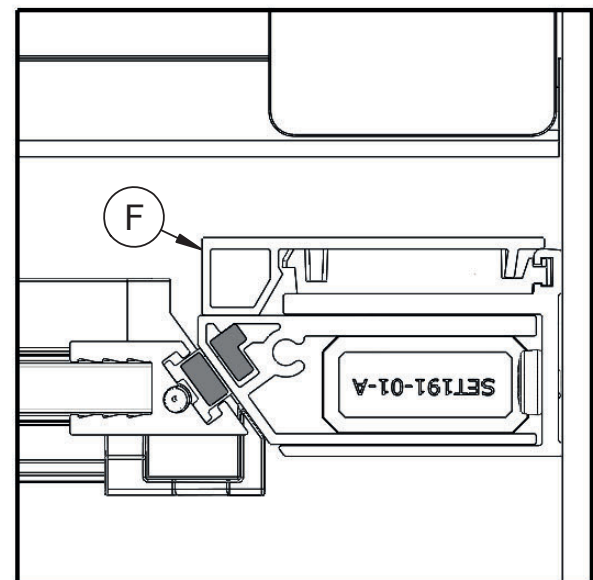
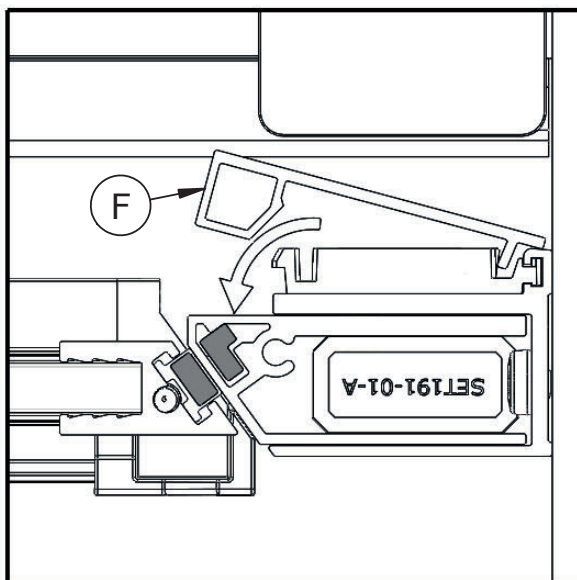

Réglage de la porte - Door adjustment
 Ajuste de la puerta - Ajuste da porta - Regolazione porta
 Afstellen van de deur - Einstellen der Tür

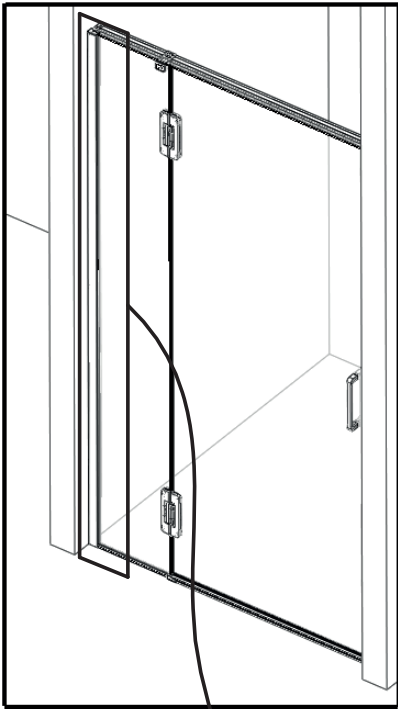

Si nécessaire, desserrer, régler puis resserrer
 If necessary, loosen, adjust and tighten
 Si es necesario, afloje, ajuste y apriete
 Se necessário, desaperte, ajuste e aperte
 Se necessario, allentare, regolare e stringere
 Draai los, indien nodig, stel af en draai vervolgens
 weer vast
 Falls erforderlich, lösen, einstellen und wieder
 festziehen

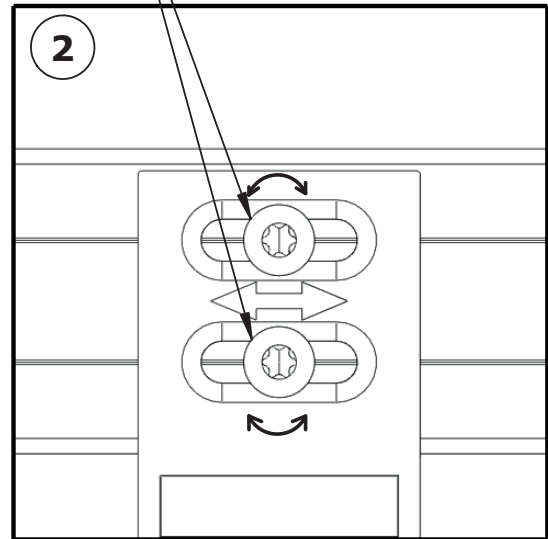
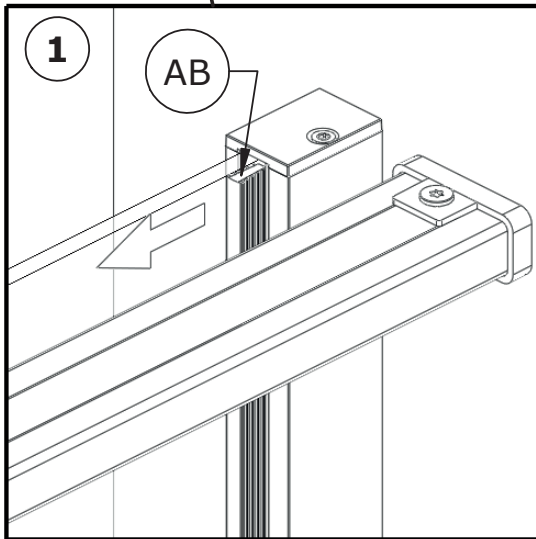

Retirer (AB) - Remove (AB) - Quitar (AB) - Retirar (AB)
 Togliere (AB) - Verwijderen (AB) - Entfernen (AB)

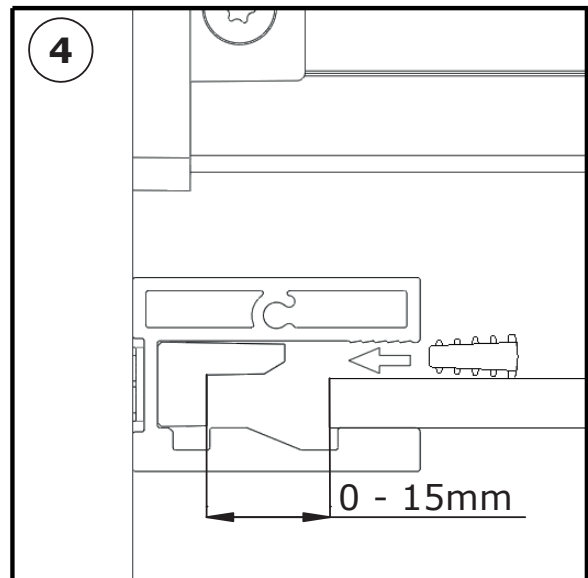
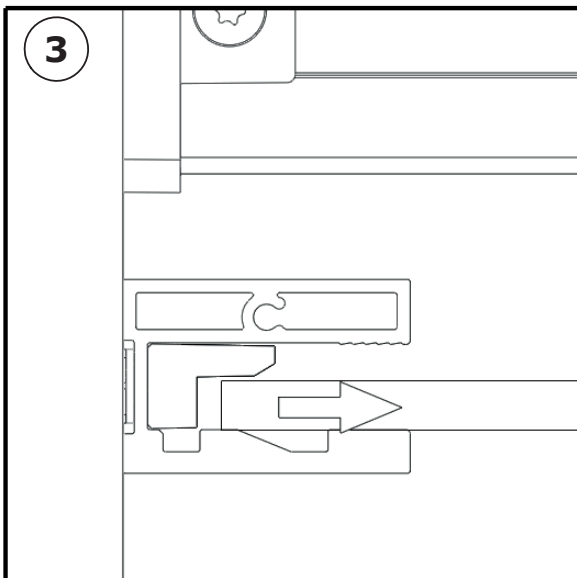

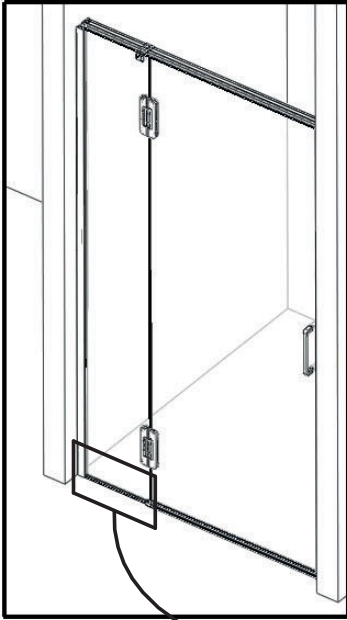

P.26

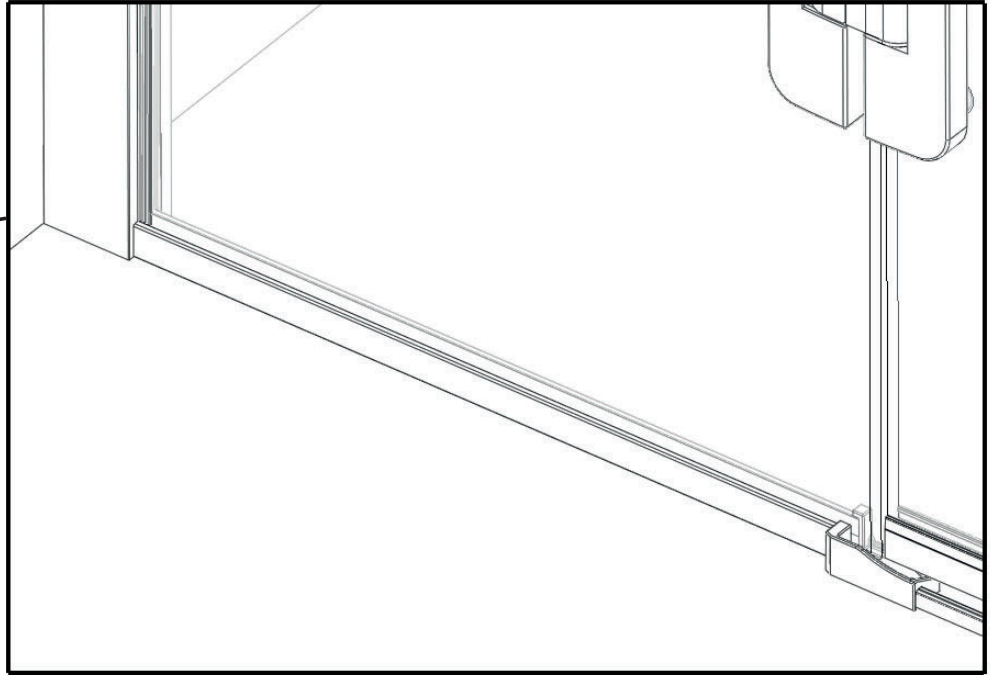

Ou - Or - O - Ou
O - Of - Oder

P.27

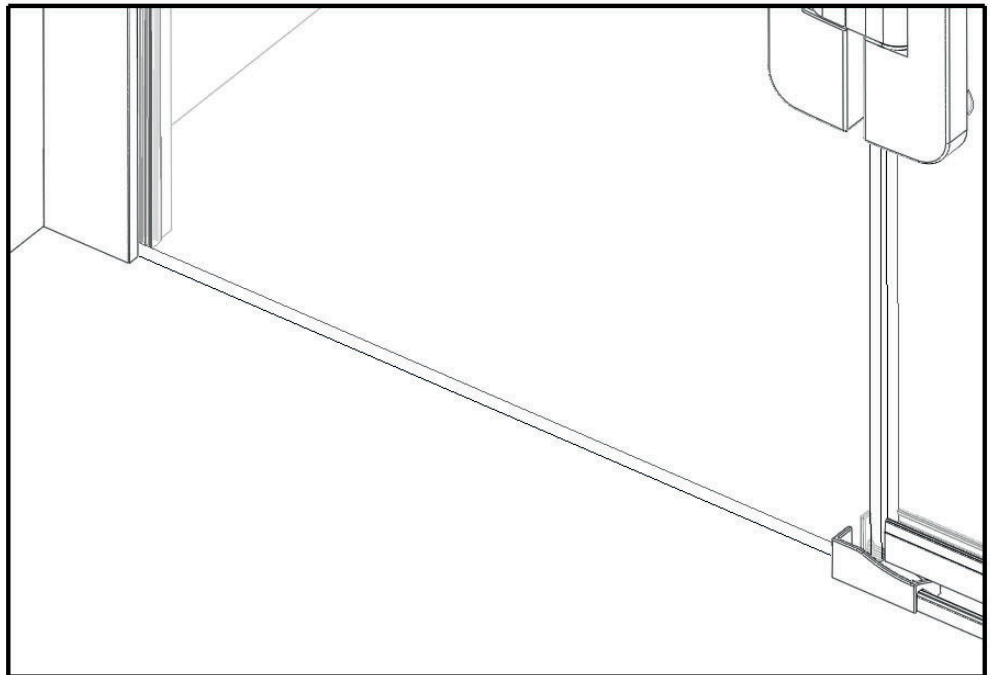

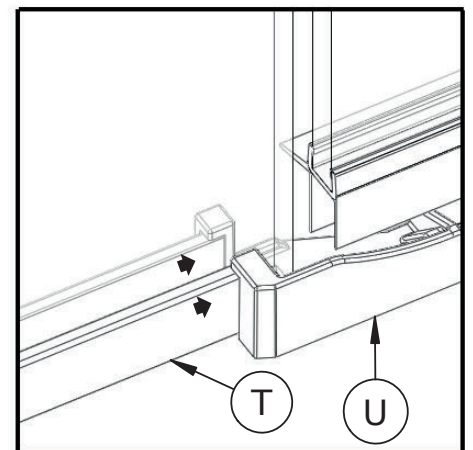
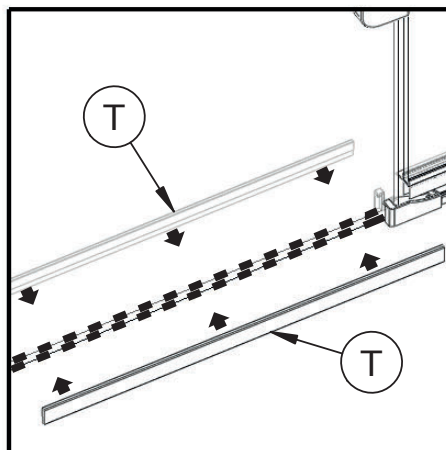
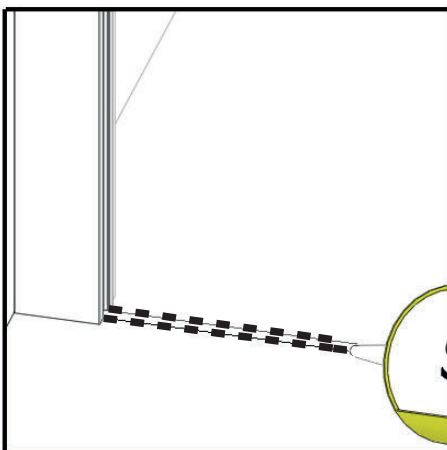
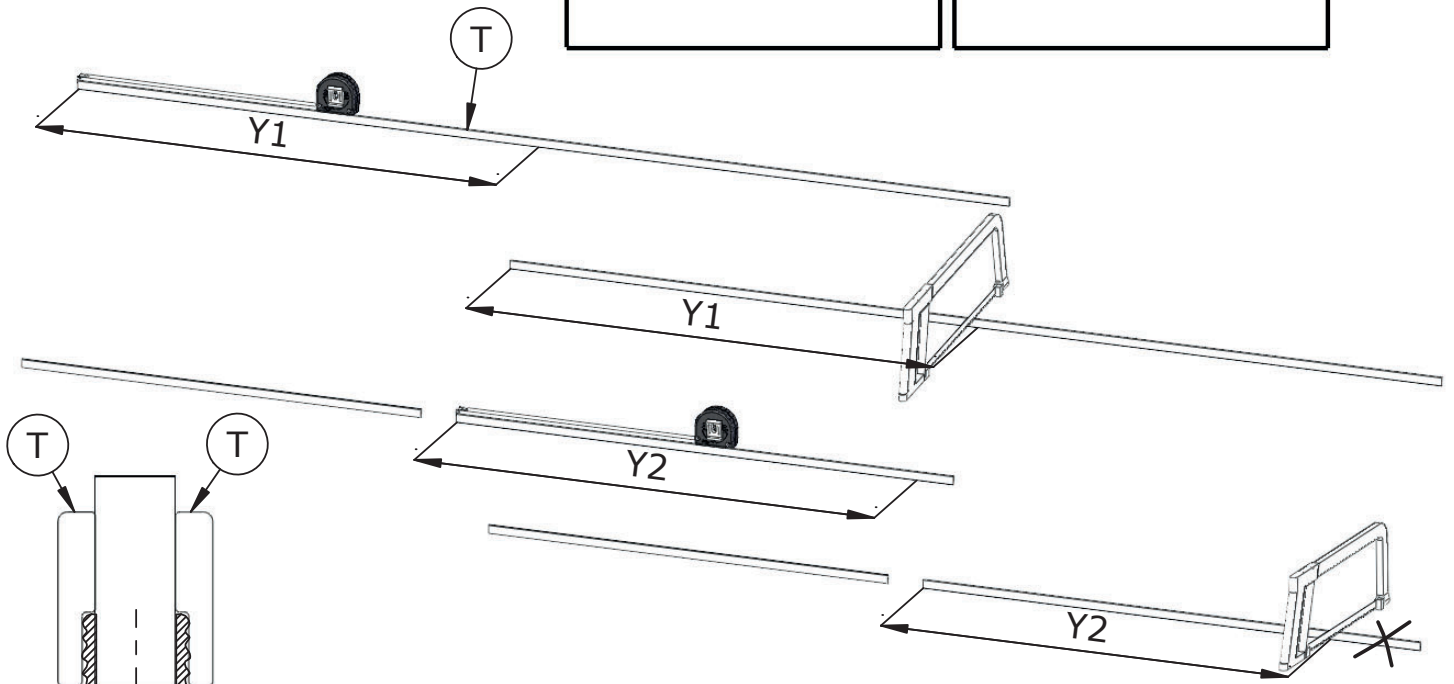
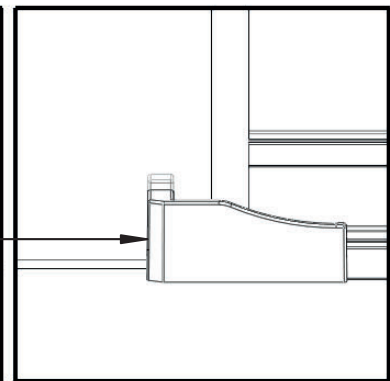
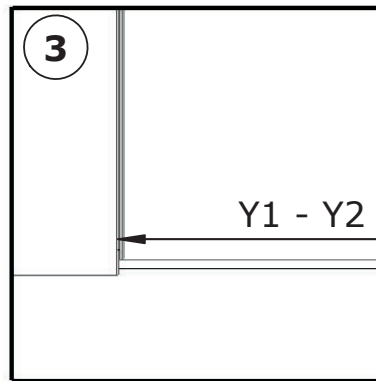
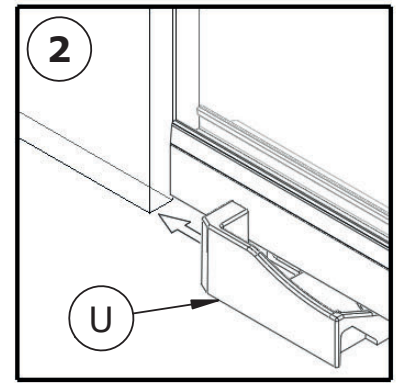
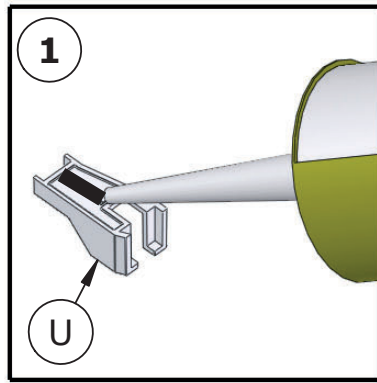
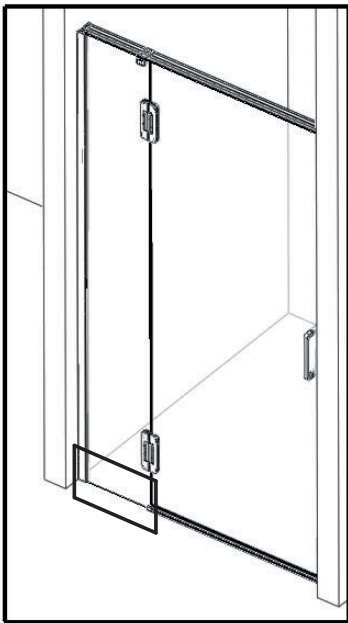

Silicone à l'intérieur et à l'extérieur - Silicone inside and outside
 Silicona por dentro y por fuera - Silicone por dentro e por fora -
 Silicone all'interno e all'esterno
 Silicone aan de binnen- en de buitenkant - Silikon innen und außen

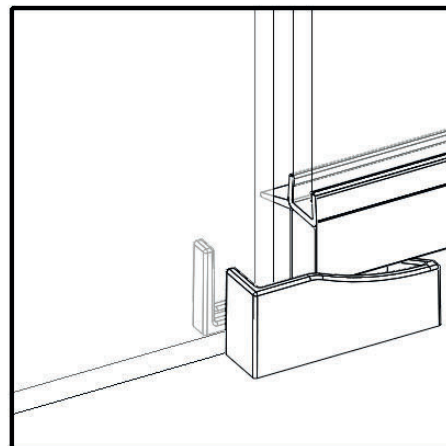
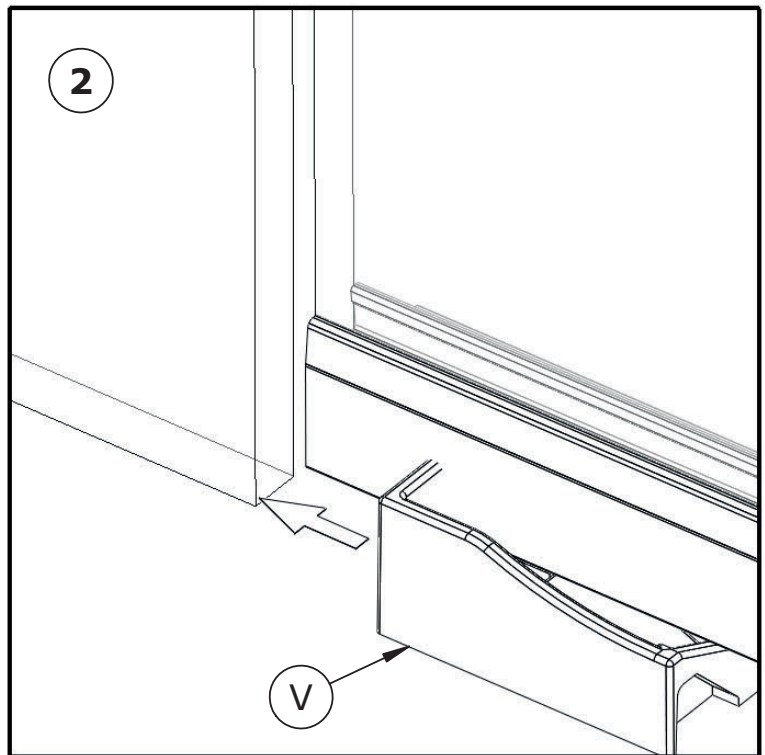
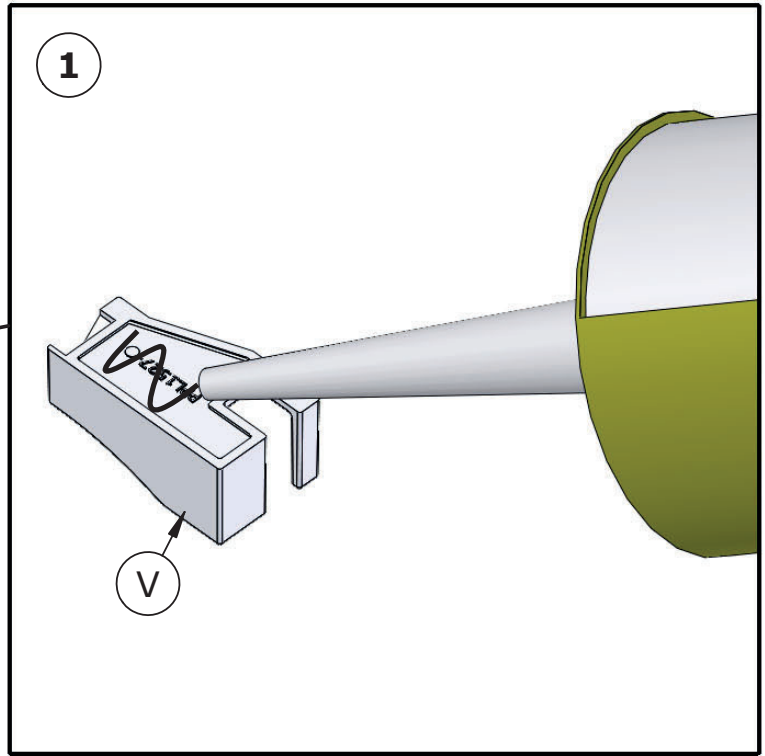
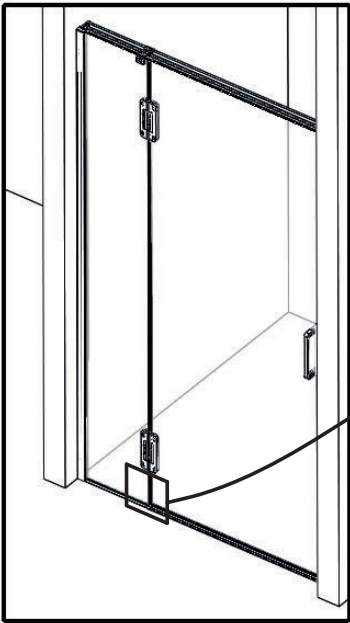

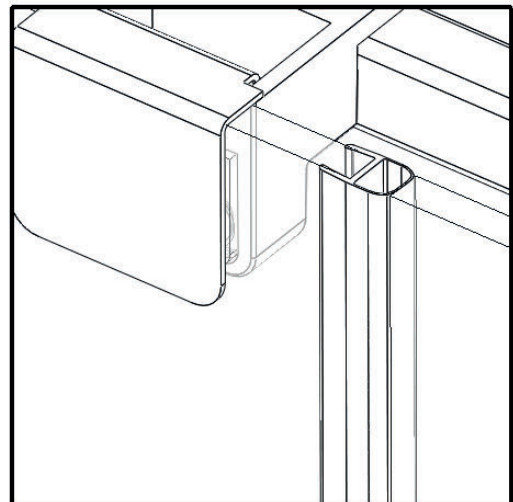
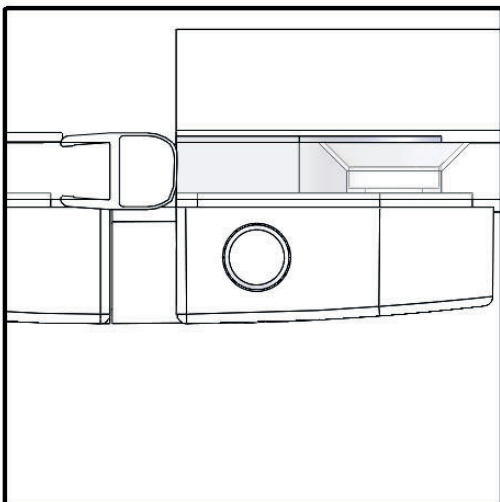
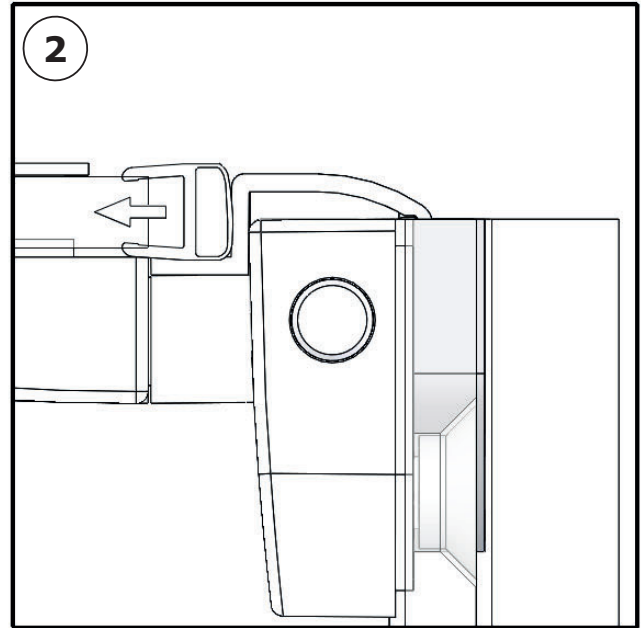
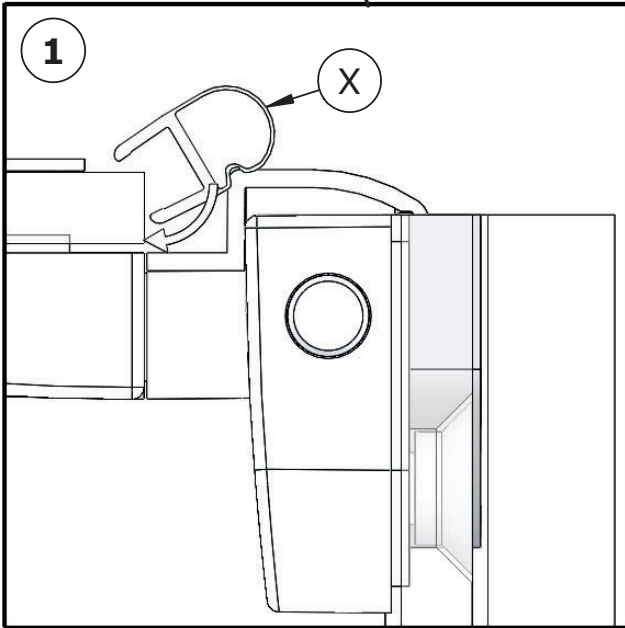
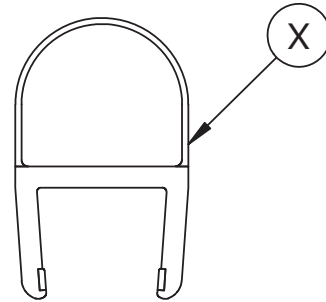
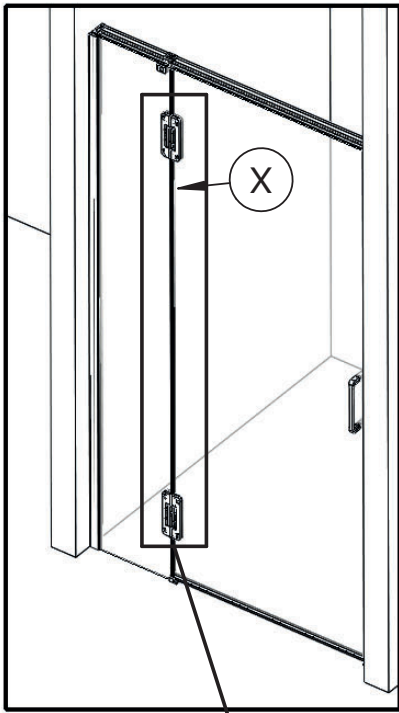

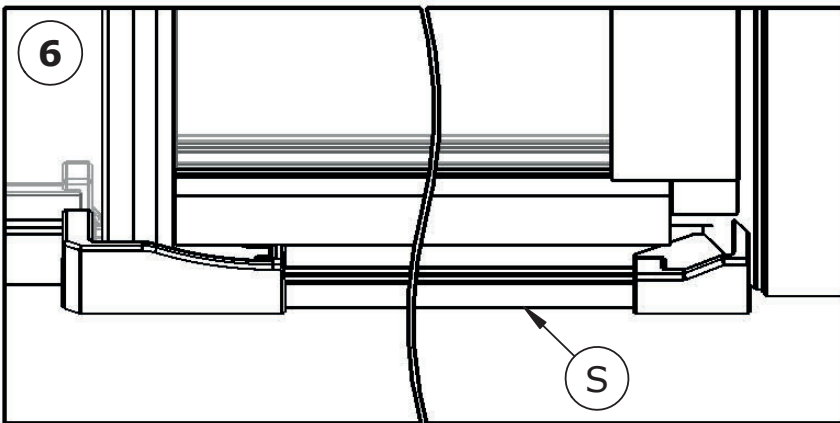
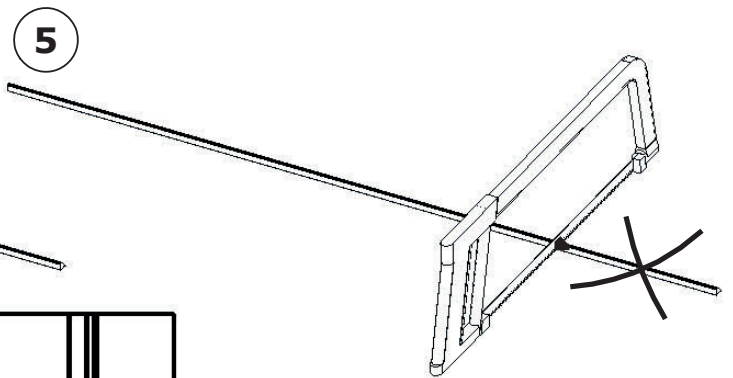
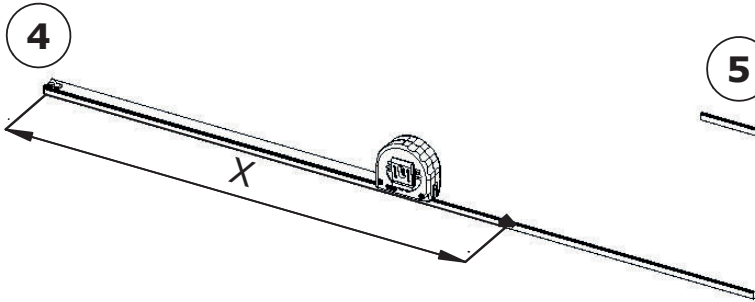
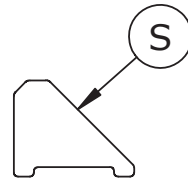
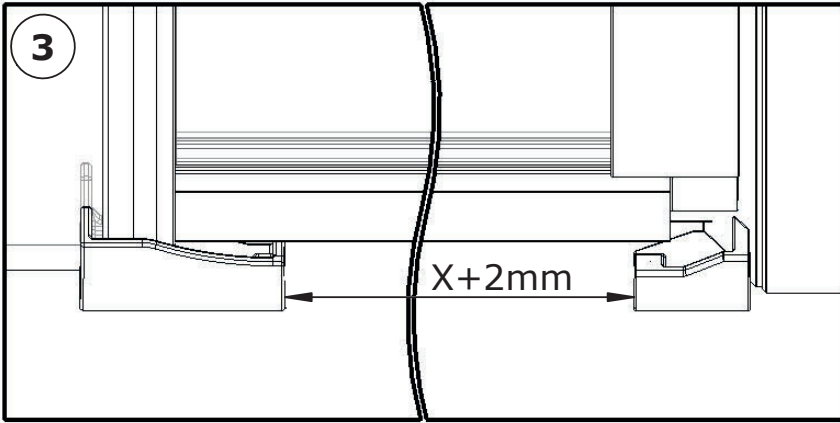
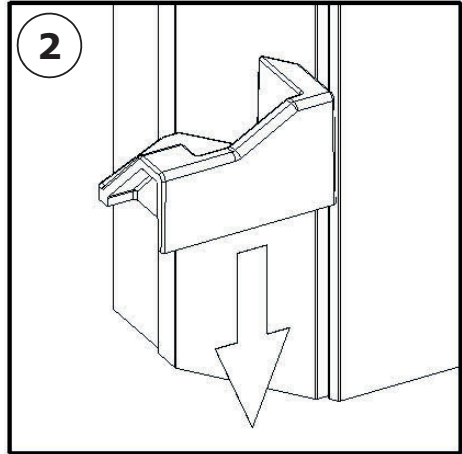
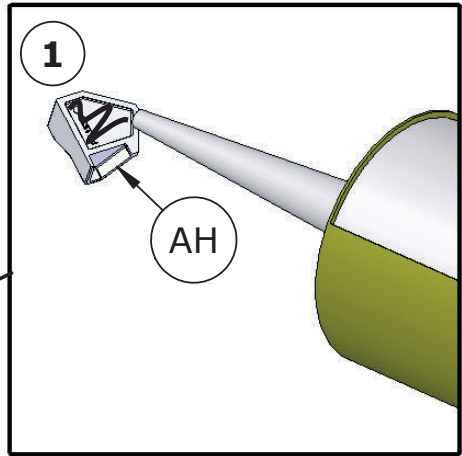
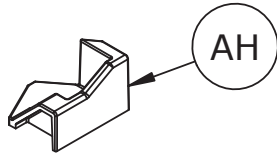
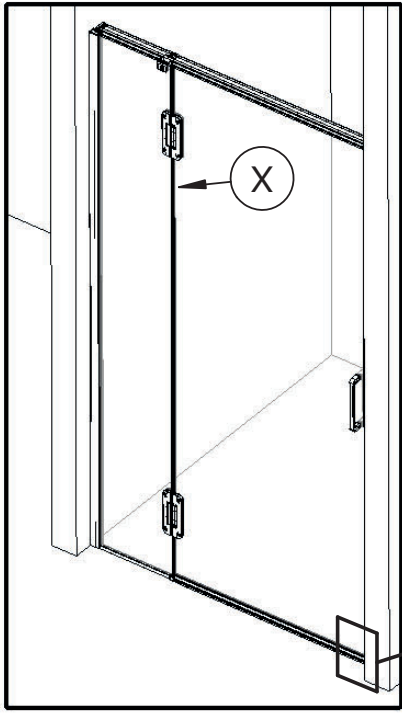

Retirer l'adhésif
Remove adhesive
Quitar el adhesivo
Retire o adesivo
Rimuovere il adesivo
Verwijder de lijm
Klebstoff entfernen

1

AG

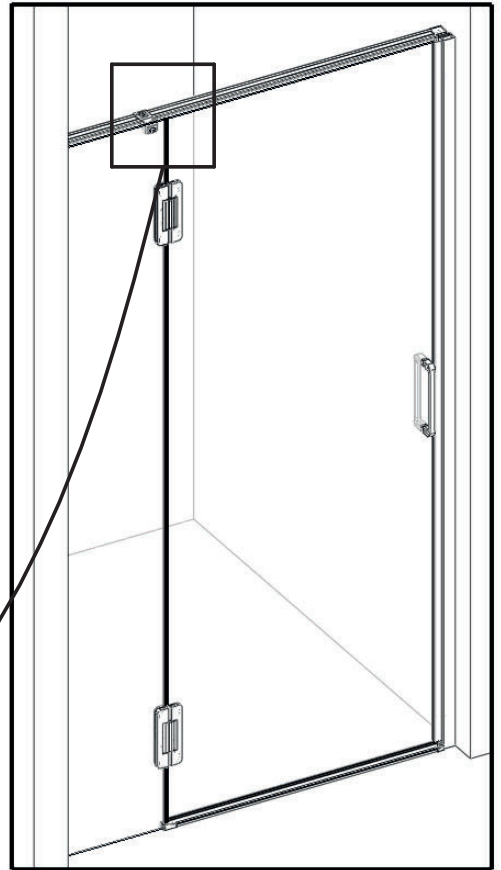
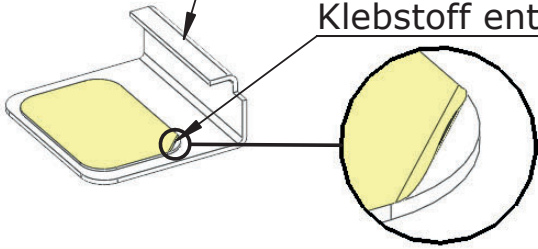

2

AG

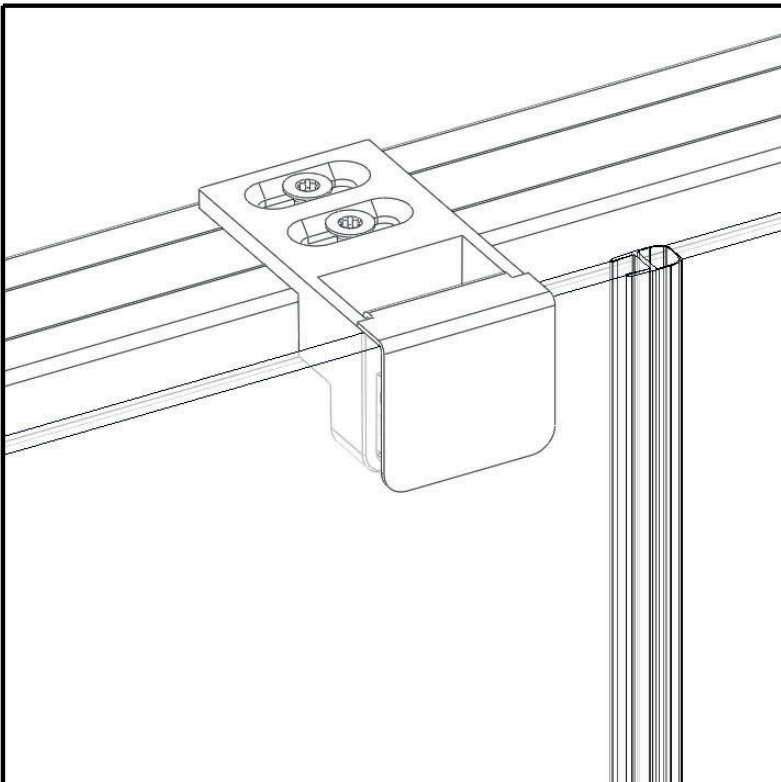
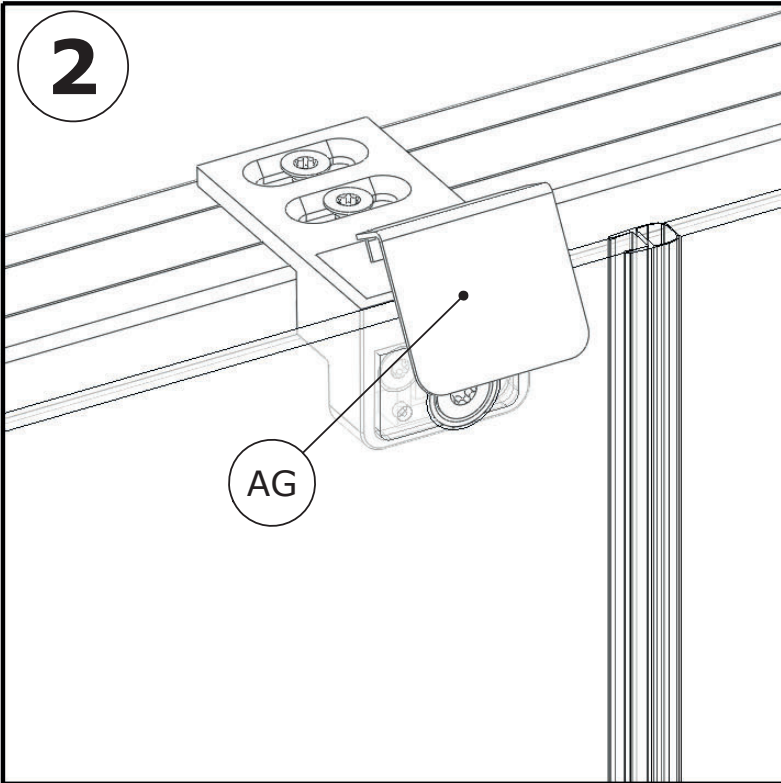

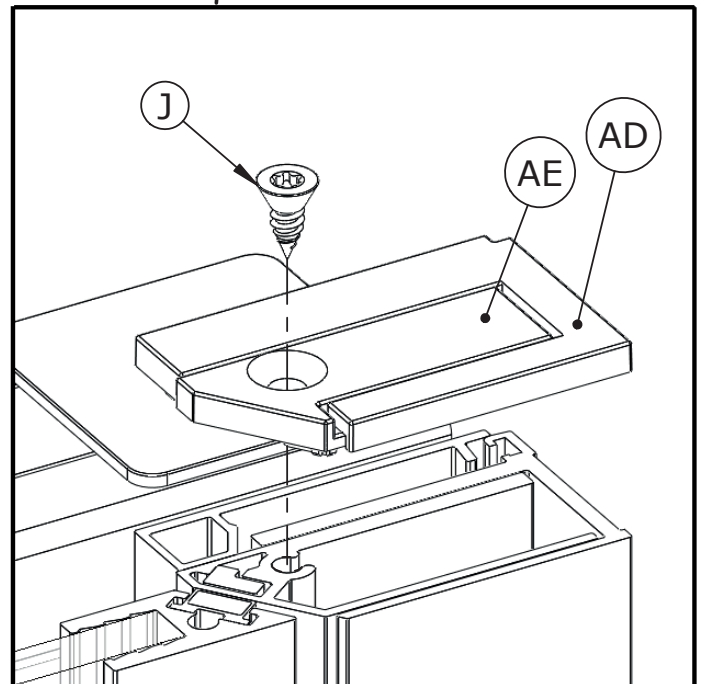
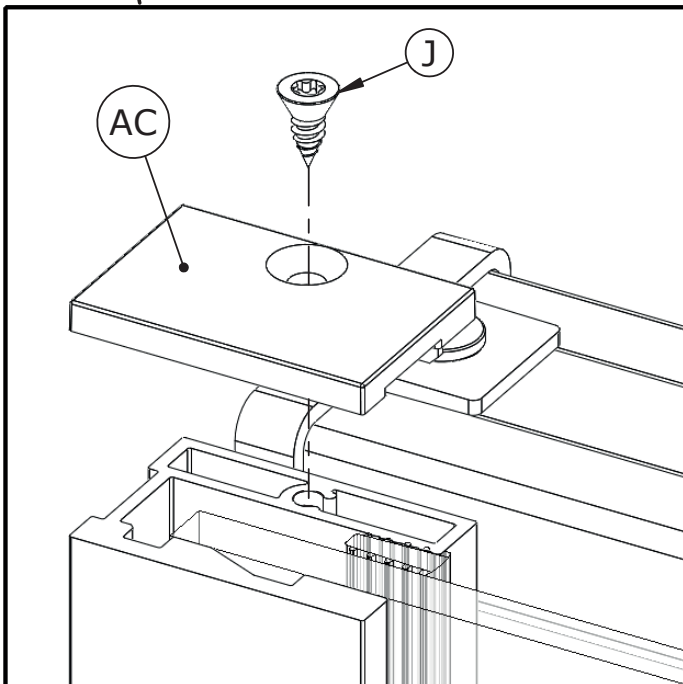
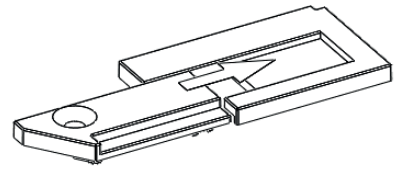
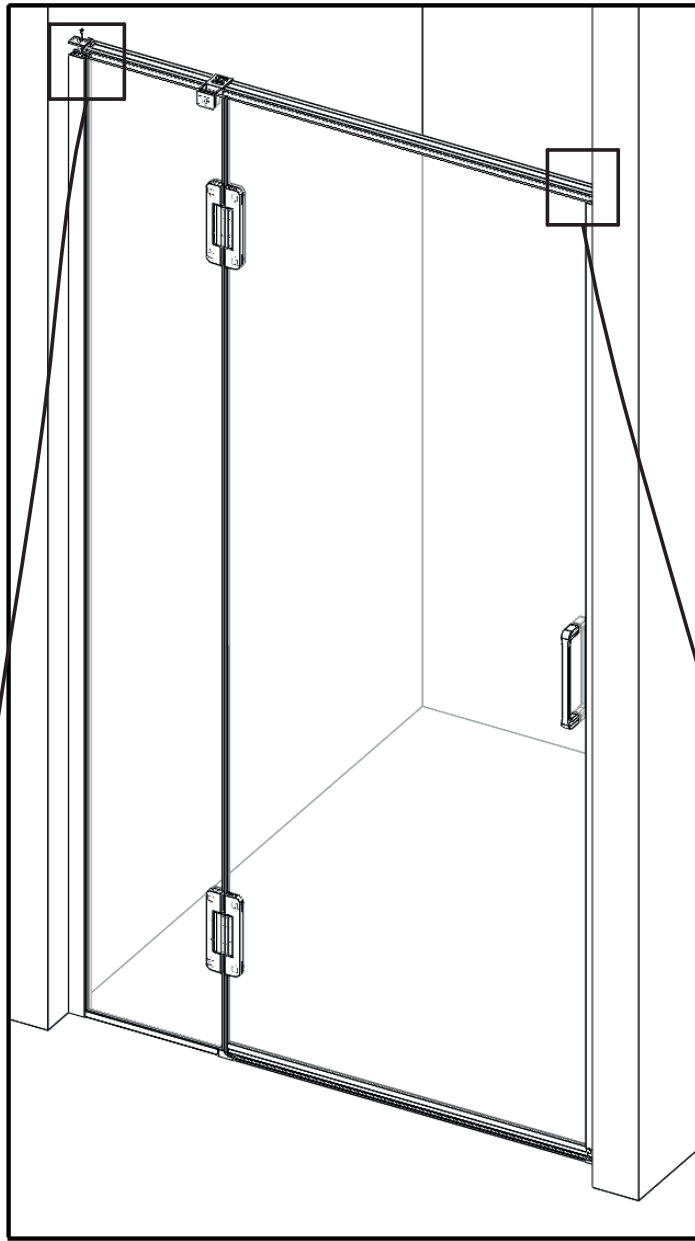

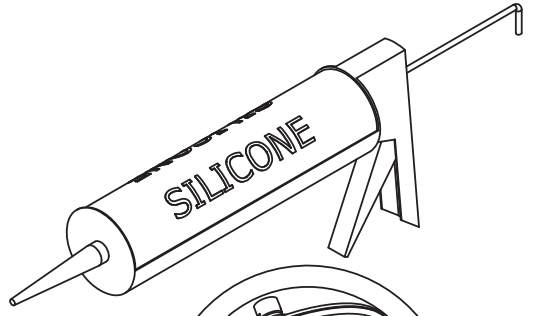
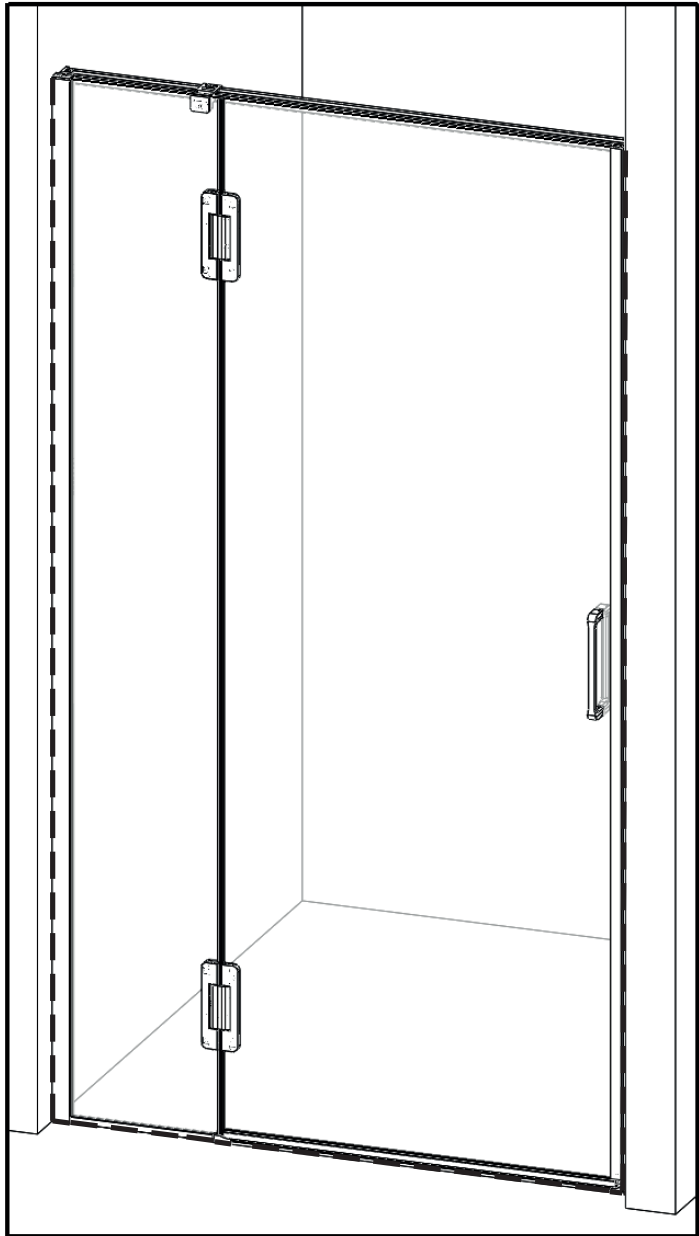

24h

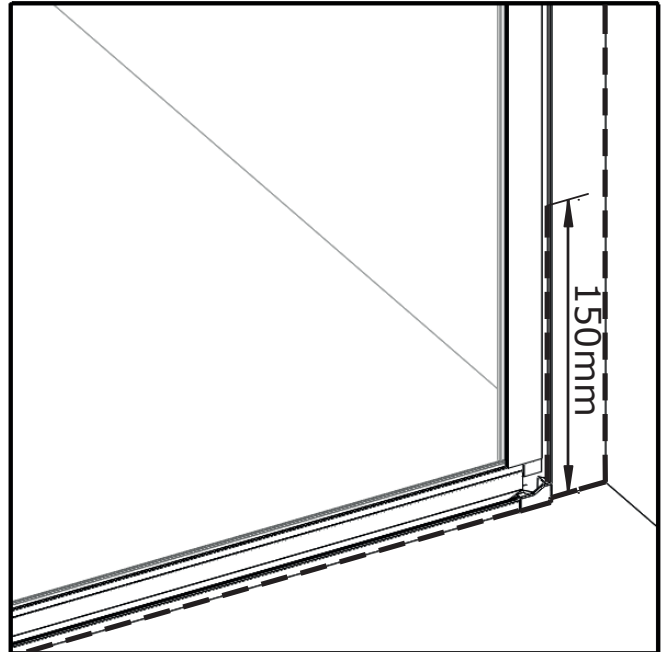
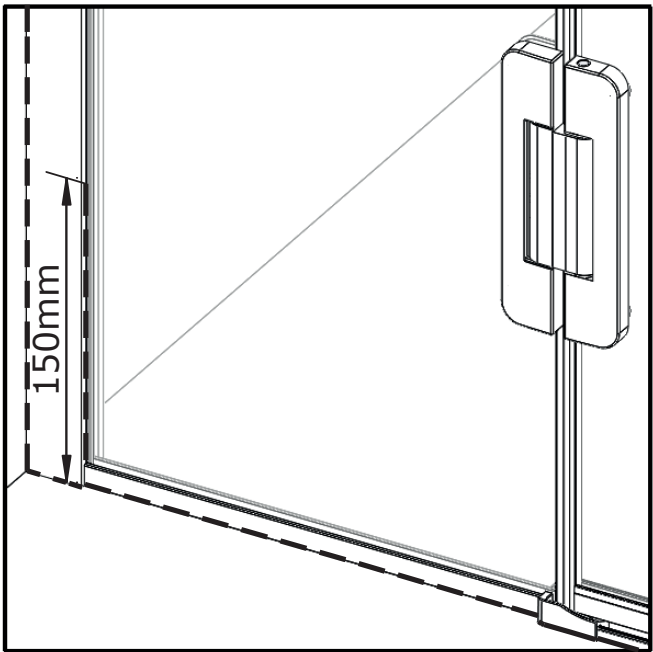

**NOTICE D'ENTRETIEN
MAINTENANCE INSTRUCTIONS
ISTRUZIONI DI MANUTENZIONE
INSTRUCCIONES DE MANTENIMIENTO
ONDERHOUDSINSTRUCTIE
WARTUNGSANLEITUNG**

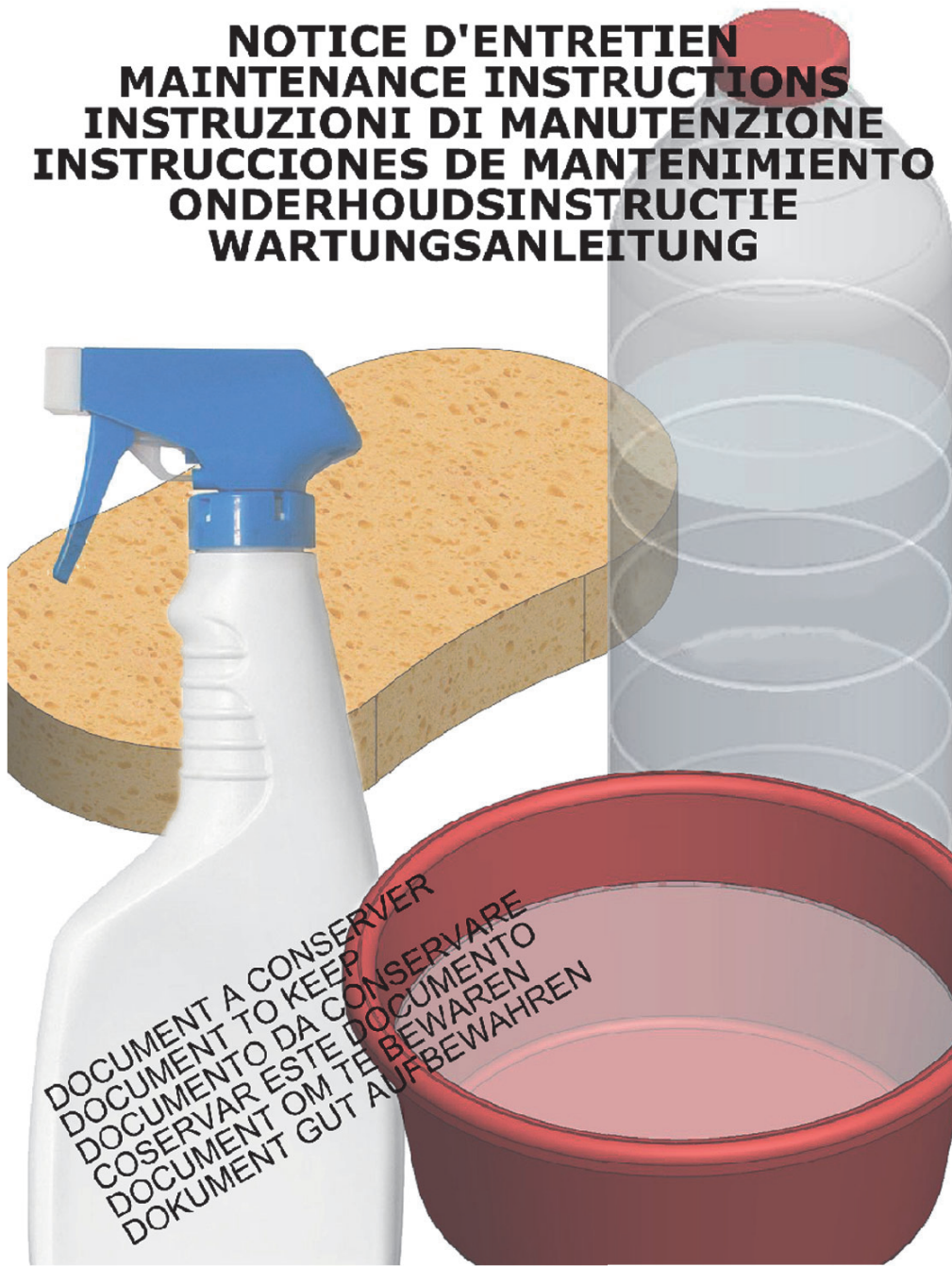

SCAN ME





AQUAPRODUCTION, Site industriel,
F - 44680 Chaumes-en-Retz

20

EN 14428

Paroi de douche, fabriquée en verre de silicate
sodo-calcique de sécurité trempé thermiquement

Aptitude au nettoyage : réussite

Résistance à l'impact/propriétés de fragmentation : réussite

Durabilité : réussite



SERVICE APRÈS-VENTE AFTER-SALES SERVICE

FRANCE

+33 (0)2 40 21 29 45

UK

+44 (0)20 8842 0033

IRELAND

+353 04697 33102

DEUTSCHLAND

+49 (0) 6074 / 30928 0

ITALIA

+39 (0382) 6181

ÖSTEREICH

+43 1 710 60 70

SUISSE/SCHWEIZ

+41 (0)32 631 04 74

ESPAÑA

+34 93 544 60 76

NEDERLAND

+31 475 487 100

BELGIQUE/BELGIË

+31 475 487 100

РОССИЯ

+7 495 258-29-51

PORTUGAL

+351 219 112 785